

5

Multiple Integrals and their Applications



5.1 INTRODUCTION TO DEFINITE INTEGRALS AND DOUBLE INTEGRALS

Definite Integrals

The concept of definite integral

$$\int_a^b f(x) dx \quad \dots(1)$$

is physically the area under a curve $y = f(x)$, (say), the x -axis and the two ordinates $x = a$ and $x = b$. It is defined as the limit of the sum

$$f(x_1)\delta x_1 + f(x_2)\delta x_2 + \dots + f(x_n)\delta x_n$$

when $n \rightarrow \infty$ and each of the lengths $\delta x_1, \delta x_2, \dots, \delta x_n$ tends to zero.

Here $\delta x_1, \delta x_2, \dots, \delta x_n$ are n subdivisions into which the range of integration has been divided and x_1, x_2, \dots, x_n are the values of x lying respectively in the 1st, 2nd, ..., n th subintervals.

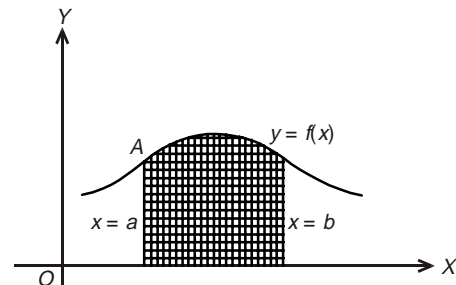

Fig. 5.1

Double Integrals

A double integral is the counter part of the above definition in two dimensions.

Let $f(x, y)$ be a single valued and bounded function of two independent variables x and y defined in a closed region A in xy plane. Let A be divided into n elementary areas $\delta A_1, \delta A_2, \dots, \delta A_n$.

Let (x_r, y_r) be any point inside the r th elementary area δA_r .

Consider the sum

$$f(x_1, y_1)\delta A_1 + f(x_2, y_2)\delta A_2 + \dots + f(x_n, y_n)\delta A_n = \sum_{r=1}^n f(x_r, y_r)\delta A_r \quad \dots(2)$$

Then the limit of the sum (2), if exists, as $n \rightarrow \infty$ and each sub-elementary area approaches to zero, is termed as 'double integral' of $f(x, y)$ over the region A and expressed as $\iint_A f(x, y) dA$.

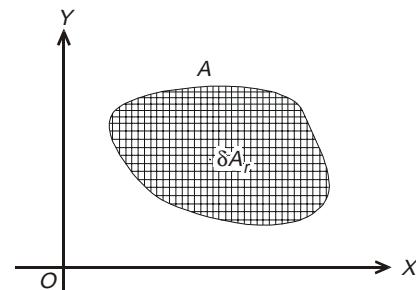

Fig. 5.2

Thus
$$\iint_A f(x, y) dA = \lim_{\substack{n \rightarrow \infty \\ \delta A_r \rightarrow 0}} \sum_{r=1}^n f(x_r, y_r) \delta A_r \quad \dots(3)$$

Observations: Double integrals are of limited use if they are evaluated as the limit of the sum. However, they are very useful for physical problems when they are evaluated by treating as successive single integrals.

Further just as the definite integral (1) can be interpreted as an area, similarly the double integrals (3) can be interpreted as a volume (see Figs. 5.1 and 5.2).

5.2 EVALUATION OF DOUBLE INTEGRAL

Evaluation of double integral $\iint_R f(x, y) dx dy$

is discussed under following three possible cases:

Case I: When the region R is bounded by two continuous curves $y = \psi(x)$ and $y = \phi(x)$ and the two lines (ordinates) $x = a$ and $x = b$.

In such a case, integration is first performed with respect to y keeping x as a constant and then the resulting integral is integrated within the limits $x = a$ and $x = b$.

Mathematically expressed as:

$$\iint_R f(x, y) dx dy = \int_{x=a}^{x=b} \left(\int_{y=\phi(x)}^{y=\psi(x)} f(x, y) dy \right) dx$$

Geometrically the process is shown in Fig. 5.3, where integration is carried out from inner rectangle (i.e., along the one edge of the 'vertical strip PQ ' from P to Q) to the outer rectangle.

Case 2: When the region R is bounded by two continuous curves $x = \phi(y)$ and $x = \Psi(y)$ and the two lines (abscissa) $y = a$ and $y = b$.

In such a case, integration is first performed with respect to x , keeping y as a constant and then the resulting integral is integrated between the two limits $y = a$ and $y = b$.

Mathematically expressed as:

$$\iint_R f(x, y) dx dy = \int_{y=a}^{y=b} \left(\int_{x=\theta(y)}^{x=\psi(y)} f(x, y) dx \right) dy$$

Geometrically the process is shown in Fig. 5.4, where integration is carried out from inner rectangle (i.e., along the one edge of the horizontal strip PQ from P to Q) to the outer rectangle.

Case 3: When both pairs of limits are constants, the region of integration is the rectangle $ABCD$ (say).

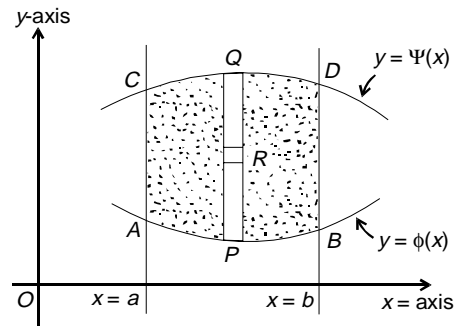

Fig. 5.3

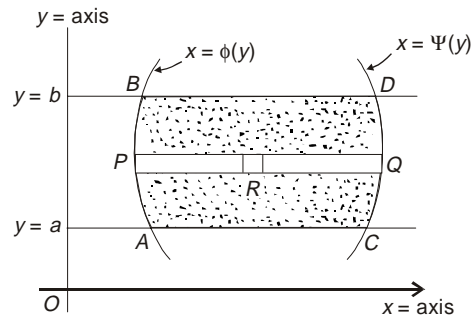

Fig. 5.4

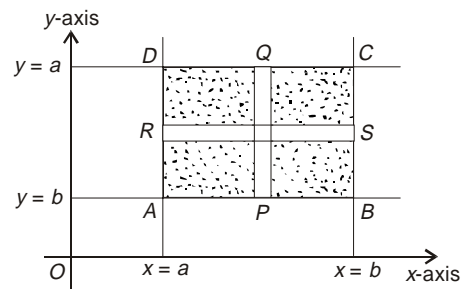

Fig. 5.5

In this case, it is immaterial whether $f(x, y)$ is integrated first with respect to x or y , the result is unaltered in both the cases (Fig. 5.5).

Observations: While calculating double integral, in either case, we proceed outwards from the innermost integration and this concept can be generalized to repeated integrals with three or more variable also.

Example 1: Evaluate $\int_0^1 \int_0^{\sqrt{1+x^2}} \frac{1}{(1+x^2+y^2)} dy dx$ [Madras 2000; Rajasthan 2005].

Solution: Clearly, here $y = f(x)$ varies from 0 to $\sqrt{1+x^2}$ and finally x (as an independent variable) goes between 0 to 1.

$$\begin{aligned} I &= \int_0^1 \left(\int_0^{\sqrt{1+x^2}} \frac{1}{(1+x^2)+y^2} dy \right) dx \\ &= \int_0^1 \left(\int_0^{\sqrt{1+x^2}} \frac{1}{a^2+y^2} dy \right) dx, \quad a^2 = (1+x^2) \\ &= \int_0^1 \left(\frac{1}{a} \tan^{-1} \frac{y}{a} \right)_0^{\sqrt{1+x^2}} dx \\ &= \int_0^1 \frac{1}{\sqrt{1+x^2}} \left(\tan^{-1} \frac{\sqrt{1+x^2}}{\sqrt{1+x^2}} - \tan^{-1} 0 \right) dx \\ &= \int_0^1 \frac{1}{\sqrt{1+x^2}} \left(\frac{\pi}{4} - 0 \right) dx = \frac{\pi}{4} \left[\log \{ x + \sqrt{1+x^2} \} \right]_0^1 \\ &= \frac{\pi}{4} \log(1 + \sqrt{2}) \end{aligned}$$

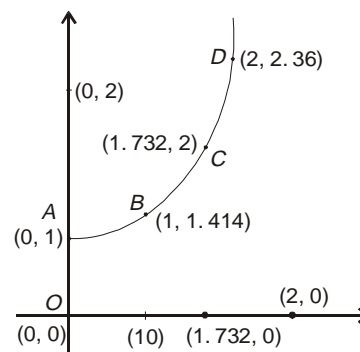

Fig. 5.6

Example 2: Evaluate $\iint e^{2x+3y} dx dy$ over the triangle bounded by the lines $x = 0$, $y = 0$ and $x + y = 1$.

Solution: Here the region of integration is the triangle $OABO$ as the line $x + y = 1$ intersects the axes at points $(1, 0)$ and $(0, 1)$. Thus, precisely the region R (say) can be expressed as:

$$0 \leq x \leq 1, 0 \leq y \leq 1 - x \text{ (Fig 5.7).}$$

$$\begin{aligned} \therefore I &= \iint_R e^{2x+3y} dx dy \\ &= \int_0^1 \left(\int_0^{1-x} e^{2x+3y} dy \right) dx \\ &= \int_0^1 \left[\frac{1}{3} e^{2x+3y} \right]_0^{1-x} dx \end{aligned}$$

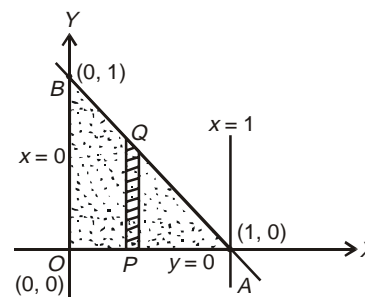

Fig. 5.7

$$\begin{aligned}
&= \frac{1}{3} \int_0^1 (e^{3-x} - e^{2x}) dx \\
&= \frac{1}{3} \left[\frac{e^{3-x}}{-1} - \frac{e^{2x}}{2} \right]_0^1 \\
&= \frac{-1}{3} \left[\left(e^2 + \frac{e^2}{2} \right) - \left(e^3 + \frac{1}{2} \right) \right] \\
&= \frac{1}{6} [2e^3 - 3e^2 + 1] = \frac{1}{6} [(2e+1)(e-1)^2].
\end{aligned}$$

Example 3: Evaluate the integral $\iint_R xy(x+y) dx dy$ over the area between the curves $y = x^2$ and $y = x$.

Solution: We have $y = x^2$ and $y = x$ which implies $x^2 - x = 0$ i.e. either $x = 0$ or $x = 1$

Further, if $x = 0$ then $y = 0$; if $x = 1$ then $y = 1$. Means the two curves intersect at points $(0, 0)$, $(1, 1)$.

\therefore The region R of integration is dotted and can be expressed as: $0 \leq x \leq 1$, $x^2 \leq y \leq x$.

$$\begin{aligned}
\therefore \iint_R xy(x+y) dx dy &= \int_0^1 \left(\int_{x^2}^x xy(x+y) dy \right) dx \\
&= \int_0^1 \left\{ x^2 \frac{y^2}{2} + x \frac{y^3}{3} \right\}_{x^2}^x dx \\
&= \int_0^1 \left\{ \left(\frac{x^4}{2} + \frac{x^4}{3} \right) - \left(\frac{x^6}{2} + \frac{x^7}{3} \right) \right\} dx \\
&= \int_0^1 \left(\frac{5}{6} x^4 - \frac{1}{2} x^6 - \frac{1}{3} x^7 \right) dx \\
&= \left[\frac{5}{6} \times \frac{x^5}{5} - \frac{1}{2} \frac{x^7}{7} - \frac{1}{3} \frac{x^8}{8} \right]_0^1 = \frac{1}{6} - \frac{1}{14} - \frac{1}{24} = \frac{3}{56}
\end{aligned}$$

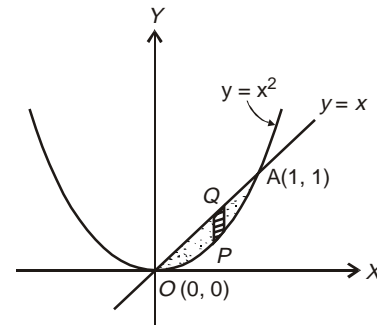

Fig. 5.8

Example 4: Evaluate $\iint (x+y)^2 dx dy$ over the area bounded by the ellipse $\frac{x^2}{a^2} + \frac{y^2}{b^2} = 1$.

[UP Tech. 2004, 05; KUK, 2009]

Solution: For the given ellipse $\frac{x^2}{a^2} + \frac{y^2}{b^2} = 1$, the region of integration can be considered as

bounded by the curves $y = -b\sqrt{1 - \frac{x^2}{a^2}}$, $y = b\sqrt{1 - \frac{x^2}{a^2}}$ and finally x goes from $-a$ to a

$$\therefore I = \iint (x + y)^2 dx dy = \int_{-a}^a \left(\int_{-b\sqrt{1-x^2/a^2}}^{b\sqrt{1-x^2/a^2}} (x^2 + y^2 + 2xy) dy \right) dx$$

$$I = \int_{-a}^a \left(\int_{-b\sqrt{1-x^2/a^2}}^{b\sqrt{1-x^2/a^2}} (x^2 + y^2) dy \right) dx$$

[Here $\int 2xy dy = 0$ as it has the same integral value for both limits i.e., the term xy , which is an odd function of y , on integration gives a zero value.]

$$I = 4 \int_0^a \left(\int_0^{b\sqrt{1-x^2/a^2}} (x^2 + y^2) dy \right) dx$$

$$I = 4 \int_0^a \left[x^2 y + \frac{y^3}{3} \right]_0^{b\sqrt{1-x^2/a^2}} dx$$

$$\Rightarrow I = 4 \int_0^a \left[x^2 b \left(1 - \frac{x^2}{a^2} \right)^{1/2} + \frac{b^3}{3} \left(1 - \frac{x^2}{a^2} \right)^{3/2} \right] dx$$

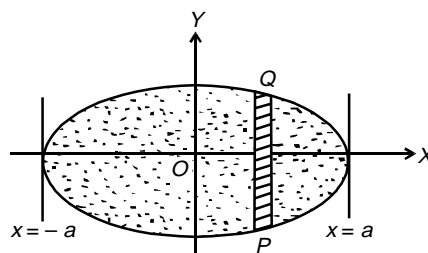

Fig. 5.9

On putting $x = a \sin \theta$, $dx = a \cos \theta d\theta$; we get

$$I = 4b \int_0^{\pi/2} \left(a^2 \sin^2 \theta \cos \theta + \frac{b^3}{3} \cos^3 \theta \right) a \cos \theta d\theta$$

$$= 4ab \int_0^{\pi/2} \left(a^2 \sin^2 \theta \cos^2 \theta + \frac{b^3}{3} \cos^4 \theta \right) d\theta$$

Now using formula $\int_0^{\pi/2} \sin^p x \cos^q x dx = \frac{1}{2} \frac{\left(\frac{p+1}{2}\right)! \left(\frac{q+1}{2}\right)!}{\left(\frac{p+q+2}{2}\right)!}$

and $\int_0^{\pi/2} \cos^n x dx = \frac{\left(\frac{n+1}{2}\right)! \sqrt{\pi}}{\left(\frac{n+2}{2}\right)! 2}$,

(in particular when $p = 0$, $q = n$)

$$\iint (x + y)^2 dx dy = 4ab \left\{ a^2 \frac{\left(\frac{3}{2}\right)! \left(\frac{3}{2}\right)!}{2 \left(\frac{3}{2}\right)!} + \frac{b^2}{3} \frac{\left(\frac{5}{2}\right)! \left(\frac{1}{2}\right)!}{2 \left(\frac{3}{2}\right)!} \right\}$$

$$= 4ab \left\{ a^2 \frac{\frac{\sqrt{\pi}}{2} \frac{\sqrt{\pi}}{2}}{2.2.1} + \frac{b^2}{3} \frac{\frac{3\sqrt{\pi}}{2} \frac{\sqrt{\pi}}{2}}{2.2.1} \right\} \quad \left| \because \left(\frac{1}{2} \right) = \sqrt{\pi} \right.$$

$$= 4ab \left\{ \frac{\pi a^2}{16} + \frac{\pi b^2}{16} \right\} = \frac{\pi ab(a^2 + b^2)}{4}$$

ASSIGNMENT 1

1. Evaluate $\int_0^1 \int_0^1 \frac{dx dy}{\sqrt{(1-x^2)(1-y^2)}}$
 2. Evaluate $\iint_R xy dx dy$, where A is the domain bounded by the x -axis, ordinate $x = 2a$ and the curve $x^2 = 4ay$. [M.D.U., 2000]
 3. Evaluate $\iint e^{ax+by} dy dx$, where R is the area of the triangle $x = 0$, $y = 0$, $ax + by = 1$ ($a > 0$, $b > 0$). [Hint: See example 2]
 4. Prove that $\int_1^2 \int_3^1 (xy + e^y) dy dx = \int_3^1 \int_1^2 (xy + e^y) dx dy$.
 5. Show that $\int_0^1 dx \int_0^1 \frac{x-y}{(x+y)^3} dy \neq \int_0^1 dy \int_0^1 \frac{x-y}{(x+y)^3} dx$.
 6. Evaluate $\int_0^\infty \int_0^\infty e^{-x^2(1+y^2)} x dx dy$ [Hint: Put $x^2(1+y^2) = t$, taking y as const.]
-

5.3 CHANGE OF ORDER OF INTEGRATION IN DOUBLE INTEGRALS

The concept of change of order of integration evolved to help in handling typical integrals occurring in evaluation of double integrals.

When the limits of given integral $\int_a^b \int_{y=\phi(x)}^{y=\psi(x)} f(x,y) dy dx$ are clearly drawn and the region of integration is demarcated, then we can well change the order of integration by performing integration first with respect to x as a function of y (along the horizontal strip PQ from P to Q) and then with respect to y from c to d .

Mathematically expressed as:

$$I = \int_c^d \int_{x=\phi(y)}^{x=\psi(y)} f(x,y) dx dy.$$

Sometimes the demarcated region may have to be split into two-to-three parts (as the case may be) for defining new limits for each region in the changed order.

Example 5: Evaluate the integral $\int_0^1 \int_0^{\sqrt{1-x^2}} y^2 dy dx$ by changing the order of integration.

[KUK, 2000; NIT Kurukshetra, 2010]

Solution: In the above integral, y on vertical strip (say PQ) varies as a function of x and then the strip slides between $x = 0$ to $x = 1$.

Here $y = 0$ is the x -axis and $y = \sqrt{1-x^2}$ i.e., $x^2 + y^2 = 1$ is the circle.

In the changed order, the strip becomes $P'Q'$, P' resting on the curve $x = 0$, Q' on the circle $x = \sqrt{1-y^2}$ and finally the strip $P'Q'$ sliding between $y = 0$ to $y = 1$.

$$\begin{aligned} \therefore I &= \int_0^1 y^2 \left(\int_0^{\sqrt{1-y^2}} dx \right) dy \\ I &= \int_0^1 y^2 [x]_0^{\sqrt{1-y^2}} dy \\ I &= \int_0^1 y^2 (1-y^2)^{\frac{1}{2}} dx \end{aligned}$$

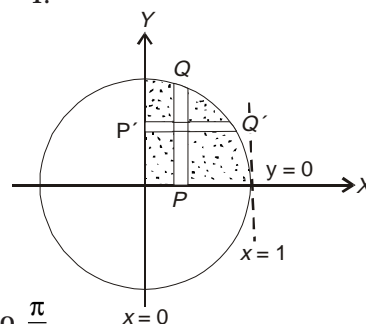

Fig. 5.10

Substitute $y = \sin \theta$, so that $dy = \cos \theta d\theta$ and θ varies from 0 to $\frac{\pi}{2}$.

$$\begin{aligned} I &= \int_0^{\frac{\pi}{2}} \sin^2 \theta \cos^2 \theta d\theta \\ I &= \frac{(2-1) \cdot (2-1) \pi}{4 \cdot 2 \cdot 2} = \frac{\pi}{16} \end{aligned}$$

$$\left[\because \int_0^{\frac{\pi}{2}} \sin^p \theta \cos^q \theta d\theta = \frac{(p-1)(p-3)\dots(q-1)(q-3)}{(p+q)(p+q-2)\dots} \times \frac{\pi}{2}, \text{ only if both } p \text{ and } q \text{ are +ve even integers} \right]$$

Example 6: Evaluate $\int_0^{4a} \int_{\frac{x^2}{4a}}^{2\sqrt{ax}} dy dx$ by changing the order of integration.
[M.D.U. 2000; PTU, 2009]

Solution: In the given integral, over the vertical strip PQ (say), if y changes as a function of x such that P lies on the curve $y = \frac{x^2}{4a}$ and Q lies on the curve $y = 2\sqrt{ax}$ and finally the strip slides between $x = 0$ to $x = 4a$.

Here the curve $y = \frac{x^2}{4a}$ i.e. $x^2 = 4ay$ is a parabola with

$$\left. \begin{aligned} y = 0 & \text{ implying } x = 0 \\ y = 4a & \text{ implying } x = \pm 4a \end{aligned} \right\}$$

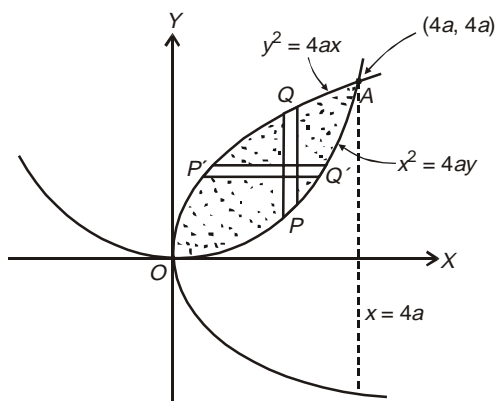

Fig. 5.11

i.e., it passes through $(0, 0)$, $(4a, 4a)$, $(-4a, 4a)$.

Likewise, the curve $y = 2\sqrt{ax}$ or $y^2 = 4ax$ is also a parabola with

$$x = 0 \Rightarrow y = 0 \text{ and } x = 4a \Rightarrow y = \pm 4a$$

i.e., it passes through $(0, 0)$, $(4a, 4a)$, $(4a, -4a)$.

Clearly the two curves are bounded at $(0, 0)$ and $(4a, 4a)$.

\therefore On changing the order of integration over the strip $P'Q'$, x changes as a function of y such that P' lies on the curve $y^2 = 4ax$ and Q' lies on the curve $x^2 = 4ay$ and finally $P'Q'$ slides between $y = 0$ to $y = 4a$.

whence

$$\begin{aligned} I &= \int_0^{4a} \left(\int_{x=\frac{y^2}{4a}}^{x=2\sqrt{ay}} dx \right) dy \\ &= \int_0^{4a} \left[x \right]_{\frac{y^2}{4a}}^{2\sqrt{ay}} dy \\ &= \int_0^{4a} \left(2\sqrt{ay} - \frac{y^2}{4a} \right) dy \\ &= \left[2\sqrt{a} \frac{y^{\frac{3}{2}}}{\frac{3}{2}} - \frac{y^3}{12a} \right]_0^{4a} = \frac{4\sqrt{a}}{3} (4a)^{\frac{3}{2}} - \frac{1}{12a} (4a)^3 \\ &= \frac{32a^2}{3} - \frac{16a^2}{3} = \frac{16a^2}{3}. \end{aligned}$$

Example 7: Evaluate $\int_0^a \int_{\frac{x}{a}}^{\sqrt{\frac{x}{a}}} (x^2 + y^2) dx dy$ by changing the order of integration.

Solution: In the given integral $\int_0^a \int_{x/a}^{\sqrt{x/a}} (x^2 + y^2) dx dy$, y varies along vertical strip PQ as a function of x and finally x as an independent variable varies from $x = 0$ to $x = a$.

Here $y = x/a$ i.e. $x = ay$ is a straight line and $y = \sqrt{x/a}$, i.e. $x = ay^2$ is a parabola.

For $x = ay$; $x = 0 \Rightarrow y = 0$ and $x = a \Rightarrow y = 1$.

Means the straight line passes through $(0, 0)$, $(a, 1)$.

For $x = ay^2$; $x = 0 \Rightarrow y = 0$ and $x = a \Rightarrow y = \pm 1$.

Means the parabola passes through $(0, 0)$, $(a, 1)$, $(a, -1)$.

Further, the two curves $x = ay$ and $x = ay^2$ intersect at common points $(0, 0)$ and $(a, 1)$.

On changing the order of integration,

$$\int_0^a \int_{x/a}^{\sqrt{x/a}} (x^2 + y^2) dx dy = \int_{y=0}^{y=1} \left(\int_{x=ay^2}^{x=ay} (x^2 + y^2) dx dy \right)$$

(at P')

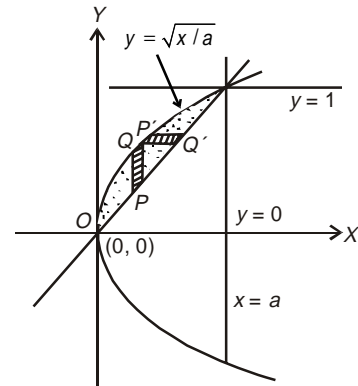

Fig. 5.12

$$\begin{aligned}
I &= \int_0^1 \left[\frac{x^3}{3} + xy^2 \right]_{ay^2}^{ay} dy \\
&= \int_0^1 \left[\left(\frac{(ay)^3}{3} + ay \cdot y^2 \right) - \left(\frac{1}{3} (ay^2)^3 + ay^2 \cdot y^2 \right) \right] dy \\
&= \int_0^1 \left[\left(\frac{a^3}{3} + a \right) y^3 - \frac{a^3}{3} y^6 - ay^4 \right] dy \\
&= \left[\left(\frac{a^3}{3} + a \right) \frac{y^4}{4} - \frac{a^3}{3} \frac{y^7}{7} - \frac{ay^5}{5} \right]_0^1 \\
&= \left[\left(\frac{a^3}{3 \times 4} - \frac{a^3}{3 \times 7} \right) + \left(\frac{a}{4} - \frac{a}{5} \right) \right] \\
&= \frac{a^3}{28} + \frac{a}{20} = \frac{a}{140} (5a^2 + 7).
\end{aligned}$$

Example 8: Evaluate $\int_0^a \int_{\sqrt{ax}}^a \frac{y^2}{\sqrt{y^4 - a^2 x^2}} dy dx$.

[SVTU, 2006]

Solution: In the above integral, y on the vertical strip (say PQ) varies as a function of x and then the strip slides between $x = 0$ to $x = a$.

Here the curve $y = \sqrt{ax}$ i.e., $y^2 = ax$ is the parabola and the curve $y = a$ is the straight line.

On the parabola, $x = 0 \Rightarrow y = 0$; $x = a \Rightarrow y = \pm a$ i.e., the parabola passes through points $(0, 0)$, (a, a) and $(a, -a)$.

On changing the order of integration,

$$\begin{aligned}
I &= \int_0^a \left(\int_{x=0}^{x=\frac{y^2}{a}} \frac{y^2}{\sqrt{y^4 - a^2 x^2}} dx \right) dy \\
&= \int_0^a \left(\int_0^{\frac{y^2}{a}} \frac{y^2}{a} \frac{1}{\sqrt{\left(\frac{y^2}{a}\right)^2 - x^2}} dx \right) dy \\
&= \int_0^a \frac{y^2}{a} \left[\sin^{-1} \frac{x}{\left(\frac{y^2}{a}\right)} \right]_0^{\frac{y^2}{a}} dy
\end{aligned}$$

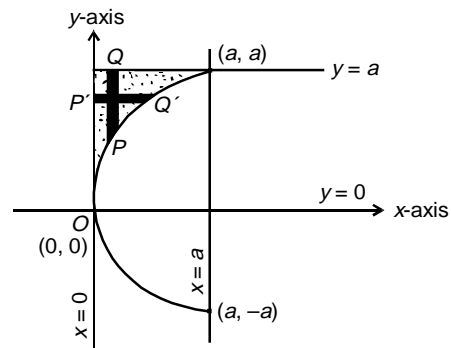

Fig. 5.13

$$\begin{aligned}
 &= \int_0^a \frac{y^2}{a} [\sin^{-1} 1 - \sin^{-1} 0] dy \\
 &= \int_0^a \frac{y^2}{a} \frac{\pi}{2} dy = \frac{\pi}{2a} \frac{y^3}{3} \Big|_0^a = \frac{\pi a^2}{6}.
 \end{aligned}$$

Example 9: Change the order of integration of $\int_0^1 \int_{x^2}^{2-x} xy \, dy \, dx$ and hence evaluate the same.
 [KUK, 2002; Cochin, 2005; PTU, 2005; UP Tech, 2005; SVTU, 2007]

Solution: In the given integral $\int_0^1 \left(\int_{x^2}^{2-x} xy \, dy \right) dx$, on the vertical strip PQ (say), y varies as a function of x and finally x as an independent variable, varies from 0 to 1.

Here the curve $y = x^2$ is a parabola with
 $y = 0$ implying $x = 0$
 $y = 1$ implying $x = \pm 1$
 i.e., it passes through $(0, 0)$, $(1, 1)$, $(-1, 1)$.

Likewise, the curve $y = 2 - x$ is straight line with

$$\left. \begin{aligned}
 y = 0 &\Rightarrow x = 2 \\
 y = 1 &\Rightarrow x = 1 \\
 y = 2 &\Rightarrow x = 0
 \end{aligned} \right\}$$

i.e. it passes through $(1, 1)$, $(2, 0)$ and $(0, 2)$

On changing the order integration, the area $OABO$ is divided into two parts $OACO$ and $ABCA$. In the area $OACO$, on the strip $P'Q'$, x changes as a function of y from $x = 0$ to $x = \sqrt{y}$. Finally y goes from $y = 0$ to $y = 1$.

Likewise in the area $ABCA$, over the strip $p''Q''$, x changes as a function of y from $x = 0$ to $x = 2 - y$ and finally the strip $P''Q''$ slides between $y = 1$ to $y = 2$.

$$\begin{aligned}
 \therefore \int_0^1 \left(\int_0^{\sqrt{y}} xy \, dx \right) dy + \int_1^2 \left(\int_0^{2-y} xy \, dx \right) dy \\
 &= \int_0^1 \left(y \frac{x^2}{2} \Big|_0^{\sqrt{y}} \right) dy + \int_1^2 \left(y \frac{x^2}{2} \Big|_0^{2-y} \right) dy \\
 &= \int_0^1 \frac{y^2}{2} dy + \int_1^2 \frac{y(2-y)^2}{2} dy \\
 &= \frac{1}{6} + \frac{1}{2} \left(2y^2 - \frac{4y^3}{3} + \frac{y^4}{4} \right) \Big|_1^2 \\
 I &= \frac{1}{6} + \frac{5}{24} = \frac{3}{8}.
 \end{aligned}$$

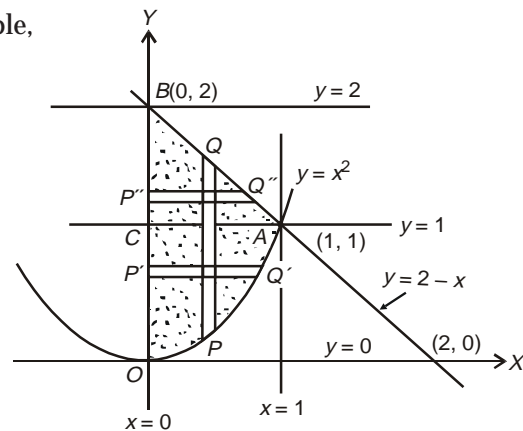

Fig. 5.14

Example 10: Evaluate $\int_0^1 \int_x^{\sqrt{2-x^2}} \frac{x}{\sqrt{x^2+y^2}} dy dx$ by changing order of integration.

[KUK, 2000; MDU, 2003; JNTU, 2005; NIT Kurukshetra, 2008]

Soluton: Clearly over the strip PQ , y varies as a function of x such that P lies on the curve $y = x$ and Q lies on the curve $y = \sqrt{2-x^2}$ and PQ slides between ordinates $x = 0$ and $x = 1$.

The curves are $y = x$, a straight line and $y = \sqrt{2-x^2}$, i.e. $x^2 + y^2 = 2$, a circle.

The common points of intersection of the two are $(0, 0)$ and $(1, 1)$.

On changing the order of integration, the same region $ONMO$ is divided into two parts $ONLO$ and $LNML$ with horizontal strips $P'Q'$ and $P''Q''$ sliding between $y = 0$ to $y = 1$ and $y = 1$ to $y = \sqrt{2}$ respectively.

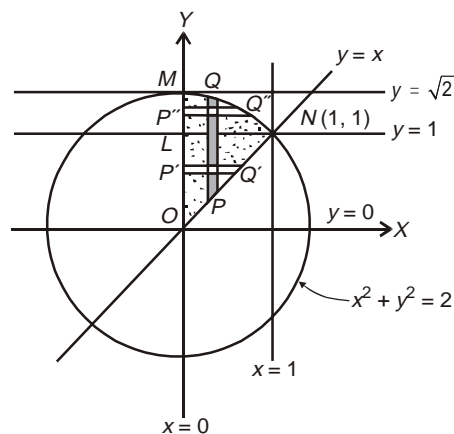

Fig. 5.15

whence
$$I = \int_0^1 \int_0^y \frac{x}{\sqrt{x^2+y^2}} dx dy + \int_1^{\sqrt{2}} \int_0^{\sqrt{2-y^2}} \frac{x}{\sqrt{x^2+y^2}} dx dy$$

Now the exp. $\frac{x}{x^2+y^2} = \frac{d}{dx} (x^2+y^2)^{\frac{1}{2}}$

$\therefore I = \int_0^1 \left[(x^2+y^2)^{\frac{1}{2}} \right]_0^y dy + \int_1^{\sqrt{2}} \left[(x^2+y^2)^{\frac{1}{2}} \right]_0^{\sqrt{2-y^2}} dy$

$$I = \int_0^1 \left[(x^2+y^2)^{\frac{1}{2}} \right]_0^y dy + \int_1^{\sqrt{2}} \left[(x^2+y^2)^{\frac{1}{2}} \right]_0^{\sqrt{2-y^2}} dy$$

$$= (\sqrt{2}-1) \frac{y^2}{2} \Big|_0^1 + \left(\sqrt{2}y - \frac{y^2}{2} \right) \Big|_0^{\sqrt{2}} = \frac{1}{2}(\sqrt{2}-1)$$

Example 11: Evaluate $\int_0^a \int_{a-\sqrt{a^2-y^2}}^{a+\sqrt{a^2-y^2}} dy dx$ by changing the order of integration.

Solution: Given $\int_{y=0}^{y=a} \left(\int_{x=a-\sqrt{a^2-y^2}}^{x=a+\sqrt{a^2-y^2}} dx \right) dy$

Clearly in the region under consideration, strip PQ is horizontal with point P lying on the curve $x = a - \sqrt{a^2 - y^2}$ and point Q lying on the curve $x = a + \sqrt{a^2 - y^2}$ and finally this strip slides between two abscissa $y = 0$ and $y = a$ as shown in Fig 5.16.

Now, for changing the order of integration, the region of integration under consideration is same but this time the strip is $P'Q'$ (vertical) which is a function of x with extremities P' and Q' at $y = 0$ and $y = \sqrt{2ax - x^2}$ respectively and slides between $x = 0$ and $x = 2a$.

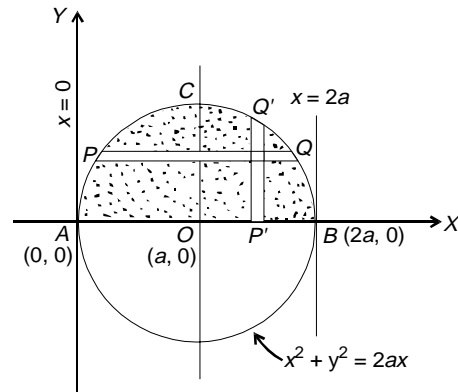

Fig. 5.16

Thus
$$I = \int_0^{2a} \left(\int_0^{\sqrt{2ax-x^2}} dy \right) dx = \int_0^{2a} [y]_0^{\sqrt{2ax-x^2}} dx$$

$$= \int_0^{2a} \sqrt{2ax-x^2} dx = \int_0^{2a} \sqrt{x} \sqrt{2a-x} dx$$

Take $\sqrt{x} = \sqrt{2a} \sin \theta$ so that $dx = 4a \sin \theta \cos \theta d\theta$,

Also, For $x = 0$, $\theta = 0$ and for $x = 2a$, $\theta = \frac{\pi}{2}$

Therefore,
$$I = \int_0^{\frac{\pi}{2}} \sqrt{2a} \sin \theta \cdot \sqrt{2a - 2a \sin^2 \theta} \cdot 4a \sin \theta \cdot \cos \theta d\theta$$

$$= 8a^2 \int_0^{\frac{\pi}{2}} \sin^2 \theta \cos^2 \theta d\theta = 8a^2 \cdot \frac{(2-1)(2-1)}{4(4-2)} \cdot \frac{\pi}{2} = \frac{\pi a^2}{2}$$

$$\left(\text{using } \int_0^{\frac{\pi}{2}} \sin^p \theta \cos^q \theta d\theta = \frac{(p-1)(p-3)\dots(q-1)(q-3)\dots \pi}{(p+q)(p+q-2)\dots 2}, \right.$$

p and q both positive even integers)

Example 12: Changing the order of integration, evaluate $\int_0^3 \int_1^{\sqrt{4-y}} (x+y) dx dy$.

[MDU, 2001; Delhi, 2002; Anna, 2003; VTU, 2005]

Solution: Clearly in the given form of integral, x changes as a function of y (viz. $x = f(y)$) and y as an independent variable changes from 0 to 3.

Thus, the two curves are the straight line $x = 1$ and the parabola, $x = \sqrt{4-y}$ and the common area under consideration is $ABQCA$.

For changing the order of integration, we need to convert the horizontal strip PQ to a vertical strip $P'Q'$ over which y changes as a function of x and it slides for values of $x = 1$ to $x = 2$ as shown in Fig. 5.17.

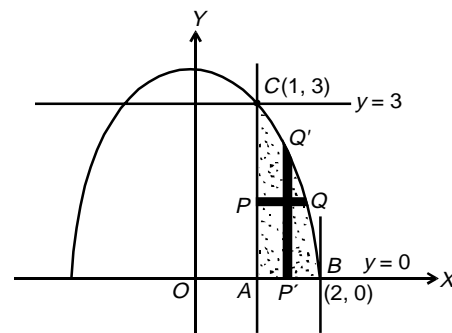

Fig. 5.17

$$\therefore I = \int_1^2 \left(\int_0^{4-x^2} (x+y) dy \right) dx = \int_1^2 \left[xy + \frac{y^2}{2} \right]_0^{4-x^2} dx$$

$$\begin{aligned}
 &= \int_1^2 \left[x(4-x^2) + \frac{(4-x^2)^2}{2} \right] dx \\
 &= \int_1^2 \left[x(4-x^2) + \left(8 + \frac{x^4}{2} - 4x^2 \right) \right] dx \\
 &= \left[2x^2 - \frac{x^4}{4} + 8x + \frac{x^5}{10} - \frac{4}{3}x^3 \right]_1^2 \\
 &= 2(2^2 - 1^2) - \frac{1}{4}(2^4 - 1^4) + 8(2 - 1) + \frac{1}{10}(2^5 - 1^5) - \frac{4}{3}(2^3 - 1^3) \\
 &= 6 - \frac{15}{4} + 8 + \frac{31}{10} - \frac{28}{3} = \frac{241}{60}.
 \end{aligned}$$

Example 13: Evaluate $\int_0^{\frac{a}{\sqrt{2}}} \int_0^{\sqrt{a^2-y^2}} \log(x^2 + y^2) dx dy$ ($a > 0$) changing the order of integration. [MDU, 2001]

Solution: Over the strip PQ (say), x changes as a function of y such that P lies on the curve $x = y$ and Q lies on the curve $x = \sqrt{a^2 - y^2}$ and

the strip PQ slides between $y = 0$ to $y = \frac{a}{\sqrt{2}}$.

Here the curves, $x = y$ is a straight line

and
$$\left. \begin{aligned}
 x = 0 &\Rightarrow y = 0 \\
 x = \frac{a}{\sqrt{2}} &\Rightarrow y = \frac{a}{\sqrt{2}}
 \end{aligned} \right\}$$

i.e. it passes through $(0, 0)$ and $\left(\frac{a}{\sqrt{2}}, \frac{a}{\sqrt{2}}\right)$

Also $x = \sqrt{a^2 - y^2}$, i.e. $x^2 + y^2 = a^2$ is a circle with centre $(0, 0)$ and radius a .

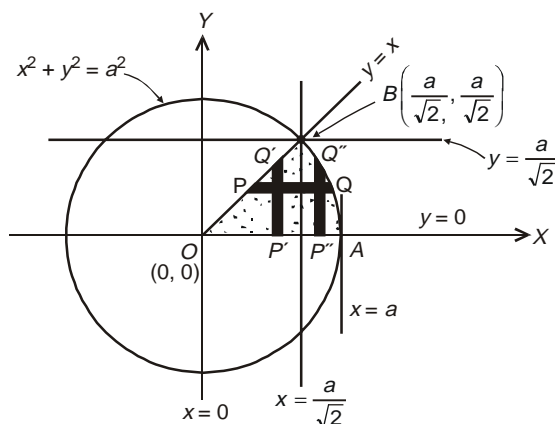

Fig. 5.18

Thus, the two curves intersect at $\left(\frac{a}{\sqrt{2}}, \frac{a}{\sqrt{2}}\right)$.

On changing the order of integration, the same region $OABO$ is divided into two parts with vertical strips $P'Q'$ and $P''Q''$ sliding between $x = 0$ to $x = \frac{a}{\sqrt{2}}$ and $x = \frac{a}{\sqrt{2}}$ to $x = a$ respectively.

Whence,
$$I = \int_0^{a/\sqrt{2}} \left(\int_0^x \log(x^2 + y^2) \cdot dy \right) dx + \int_{a/\sqrt{2}}^a \left(\int_0^{\sqrt{a^2-x^2}} \log(x^2 + y^2) \cdot 1 dy \right) dx \quad \dots(1)$$

Now,

$$\int \log(x^2 + y^2) 1 dy = \left[\log(x^2 + y^2) \cdot y - \int \frac{1}{x^2 + y^2} 2y \cdot y dy \right]$$

Ist Function IIInd Function

$$= \left[y \log(x^2 + y^2) - 2 \int \frac{y^2 + x^2 - x^2}{x^2 + y^2} dy \right]$$

$$= \left[y \log(x^2 + y^2) - 2y + 2x^2 \int \frac{1}{(x^2 + y^2)} dy \right]$$

$$= \left[y \log(x^2 + y^2) - 2y + 2x^2 \left(\frac{1}{x} \tan^{-1} \frac{y}{x} \right) \right] \quad \dots (2)$$

On using (2),

$$I_1 = \int_0^{a/\sqrt{2}} \left[y \log(x^2 + y^2) - 2y + 2x \left(\tan^{-1} \frac{y}{x} \right) \right] dx$$

$$= \int_0^{a/\sqrt{2}} [x \log 2x^2 - 2x + 2x \tan^{-1} 1] dx$$

$$= \int_0^{a/\sqrt{2}} \left[x \log 2x^2 - 2x + 2x \frac{\pi}{4} \right] dx$$

$$= \int_0^{a/\sqrt{2}} x \log 2x^2 dx + 2 \left(\frac{\pi}{4} - 1 \right) \int_0^{a/\sqrt{2}} x dx$$

For first part, let $2x^2 = t$ so that $4x dx = dt$ and limits are $t = 0$ and $t = a^2$.

$$\therefore I_1 = \int_0^{a^2} \log t \cdot \frac{dt}{4} + 2 \left(\frac{\pi}{4} - 1 \right) \left. \frac{x^2}{2} \right|_0^{a/\sqrt{2}}$$

$$= \frac{1}{4} t (\log t - 1) \Big|_0^{a^2} + \left(\frac{\pi}{4} - 1 \right) \frac{a^2}{2}, \text{ (By parts with } \log t = \log t \cdot 1)$$

$$= \frac{a^2}{4} (\log a^2 - 1) + \frac{\pi a^2}{8} - \frac{a^2}{2} \quad \dots (3)$$

Again, using (2),

$$I_2 = \int_{a/\sqrt{2}}^a \left[y \log(x^2 + y^2) - 2y + 2x \left(\tan^{-1} \frac{y}{x} \right) \right]_{\sqrt{a^2 - x^2}} dx \quad \dots (4)$$

$$\Rightarrow \int_{a/\sqrt{2}}^a \left[\sqrt{a^2 - x^2} \log a^2 - 2\sqrt{a^2 - x^2} + 2x \tan^{-1} \frac{\sqrt{a^2 - x^2}}{x} \right] dx$$

Let $x = a \sin \theta$ so that $dx = a \cos \theta d\theta$ and limits, $\frac{\pi}{4}$ to $\frac{\pi}{2}$

$$\begin{aligned} \therefore I_2 &= \int_{\pi/4}^{\pi/2} \left[(\log a^2 - 2) \sqrt{a^2 - a^2 \sin^2 \theta} + 2a \sin \theta \tan^{-1} \frac{\sqrt{a^2 - a^2 \sin^2 \theta}}{a \sin \theta} \right] a \cos \theta d\theta \\ &= \int_{\pi/4}^{\pi/2} a^2 (\log a^2 - 2) \cos^2 \theta d\theta + a^2 \int_{\pi/4}^{\pi/2} 2 \sin \theta \cos \theta \tan^{-1}(\cot \theta) d\theta \\ &= a^2 (\log a^2 - 2) \int_{\pi/4}^{\pi/2} \frac{(1 + \cos 2\theta)}{2} d\theta + a^2 \int_{\pi/4}^{\pi/2} \sin 2\theta \tan^{-1} \left(\tan \left(\frac{\pi}{2} - \theta \right) \right) d\theta \\ &= \frac{a^2}{2} (\log a^2 - 2) \left[\theta + \frac{\sin 2\theta}{4} \right]_{\pi/4}^{\pi/2} + a^2 \int_{\pi/4}^{\pi/2} \left(\frac{\pi}{2} - \theta \right) \sin 2\theta d\theta \\ &\qquad\qquad\qquad \begin{array}{cc} \text{Ist} & \text{IInd} \\ \text{Fun.} & \text{Fun.} \end{array} \\ &= \frac{a^2}{2} (\log a^2 - 2) \left[\left(\frac{\pi}{2} - \frac{\pi}{4} \right) - \frac{1}{2} \right] + a^2 \left[\left(\frac{\pi}{2} - \theta \right) \left(\frac{-\cos 2\theta}{2} \right) \right]_{\pi/4}^{\pi/2} - \int_{\pi/4}^{\pi/2} (-1) \left(\frac{-\cos 2\theta}{2} \right) d\theta \\ I_2 &= \frac{a^2}{2} (\log a^2 - 2) \left(\frac{\pi}{4} - \frac{1}{2} \right) - \frac{a^2}{2} \int_{\pi/4}^{\pi/2} \cos 2\theta d\theta, \left(\frac{\pi}{2} - \theta \right) \left(\frac{-\cos 2\theta}{2} \right) \text{ is zero for both} \\ &\text{the limits)} \\ &= \left(\frac{\pi a^2}{8} \log a^2 - \frac{\pi a^2}{4} + \frac{a^2}{2} - \frac{a^2}{4} \log a^2 \right) - \frac{a^2}{4} (\sin 2\theta)_{\pi/4}^{\pi/2} \\ &= \left(\frac{\pi a^2}{8} \log a^2 - \frac{\pi a^2}{4} + \frac{a^2}{2} - \frac{a^2}{4} \log a^2 \right) + \frac{a^2}{4} \qquad \dots(5) \end{aligned}$$

On using results (3) and (5), we get

$$\begin{aligned} I &= I_1 + I_2 \\ &= \left(\frac{a^2}{4} \log a^2 - \frac{a^2}{4} + \frac{\pi a^2}{8} - \frac{a^2}{2} \right) + \left(\frac{\pi a^2}{8} \log a^2 - \frac{\pi a^2}{4} + \frac{a^2}{2} - \frac{a^2}{4} \log a^2 + \frac{a^2}{4} \right) \\ &= \frac{\pi a^2}{8} \log a^2 - \frac{\pi a^2}{8} = \frac{\pi a^2}{8} (\log a^2 - 1) \\ &= \frac{\pi a^2}{8} (2 \log a - 1) = \frac{\pi a^2}{4} \left(\log a - \frac{1}{2} \right). \end{aligned}$$

Example 14: Evaluate by changing the order of integration. $\int_0^{\infty} \int_0^x x e^{-x^2/y} dx dy$

[VTU, 2004; UP Tech., 2005; SVTU, 2006; KUK, 2007; NIT Kurukshetra, 2007]

Solution: We write $\int_0^{\infty} \int_0^x x e^{-x^2/y} dx dy = \int_{x=0(=a)}^{x=\infty(=b)} \int_{y=f_1(x)=0}^{y=f_2(x)=x} x e^{-x^2/y} dx dy$

Here first integration is performed along the vertical strip with y as a function of x and then x is bounded between $x = 0$ to $x = \infty$.

We need to change, x as a function of y and finally the limits of y . Thus the desired geometry is as follows:

In this case, the strip PQ changes to $P'Q'$ with x as function of y , $x_1 = y$ and $x_2 = \infty$ and finally y varies from 0 to ∞ .

Therefore Integral

$$I = \int_0^{\infty} \int_y^{\infty} x e^{-x^2/y} dx dy$$

Put $x^2 = t$ so that $2x dx = dt$ Further, for $\left. \begin{array}{l} x = y, \quad t = y^2 \\ x = \infty, \quad t = \infty \end{array} \right\}$

$$\begin{aligned} I &= \int_0^{\infty} \int_{y^2}^{\infty} e^{-t/y} \frac{dt}{2} dy, \\ &= \frac{1}{2} \int_0^{\infty} \left(\left[\frac{e^{-t/y}}{-1/y} \right]_{y^2}^{\infty} \right) dy \\ &= \int_0^{\infty} -\frac{y}{2} [0 - e^{-y}] dy \\ &= \int_0^{\infty} \frac{y e^{-y}}{2} dy \quad (\text{By parts}) \\ &= \frac{1}{2} \left[y \left(\frac{e^{-y}}{-1} \right) \right]_0^{\infty} - \int_0^{\infty} 1 \frac{e^{-y}}{-1} dy \Bigg|_0^{\infty} \\ &= \frac{1}{2} [-y e^{-y} - e^{-y}]_0^{\infty} \\ &= \frac{1}{2} [(0) - (0 - 1)] = \frac{1}{2}. \end{aligned}$$

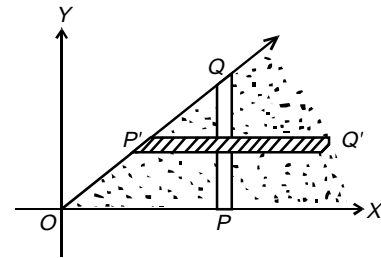

Fig. 5.19

Example 15: Evaluate the integral $\int_0^{\infty} \int_x^{\infty} \frac{e^{-y}}{-y} dy dx$.

[NIT Jalandhar, 2004, 2005; VTU, 2007]

Soluton: In the given integral, integration is performed first with respect to y (as a function of x along the vertical strip say PQ , from P to Q) and then with respect to x from 0 to ∞ .

On changing the order, of integration integration is performed first along the horizontal strip $P'Q'$ (x as a function of y) from P' to Q' and finally this strip $P'Q'$ slides between the limits $y = 0$ to $y = \infty$.

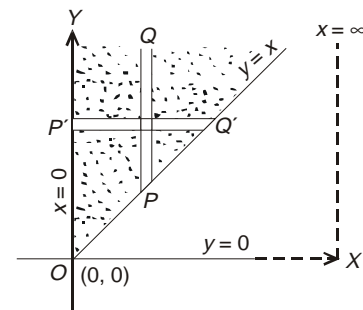

Fig. 5.20

$$\begin{aligned} \therefore I &= \int_0^\infty \frac{e^{-y}}{y} \left(\int_0^y dx \right) dy \\ &= \int_0^\infty \frac{e^{-y}}{y} (y) dy = \int_0^\infty e^{-y} dy \\ &= \frac{e^{-y}}{-1} \Big|_0^\infty = -1 \left(\frac{1}{e^\infty} - \frac{1}{e^0} \right) \\ &= -1(0 - 1) = 1 \end{aligned}$$

Example 16: Change the order of integration in the double integral $\int_0^{2a} \int_{\sqrt{2ax-x^2}}^{\sqrt{2ax}} f(x, y) dx dy$.

[Rajasthan, 2006; KUK, 2004-05]

Solution: Clearly from the expressions given above, the region of integration is described by a line which starts from $x = 0$ and moving parallel to itself goes over to $x = 2a$, and the extremities of the moving line lie on the parts of the circle $x^2 + y^2 - 2ax = 0$ the parabola $y^2 = 2ax$ in the first quadrant.

For change and of order of integration, we need to consider the same region as describe by a line moving parallel to x -axis instead of Y -axis.

In this way, the domain of integration is divided into three sub-regions I, II, III to each of which corresponds a double integral.

Thus, we get

$$\int_0^{2a} \int_{\sqrt{x^2-2ax}}^{\sqrt{2ax}} f(x, y) dy dx = \int_0^a \int_{y^2/2a}^{a-\sqrt{a^2-y^2}} f(x, y) dy dx$$

Part I

$$+ \int_0^a \int_{a+\sqrt{a^2-y^2}}^{2a} f(x, y) dy dx + \int_a^{2a} \int_{y^2/2a}^{2a} f(x, y) dy dx$$

Part II

Part III

Example 17: Find the area bounded by the lines $y = \sin x$, $y = \cos x$ and $x = 0$.

Solution: See Fig 5.22.

Clearly the desired area is the dotted portion where along the strip PQ , P lies on the curve $y = \sin x$ and Q lies on the curve $y = \cos x$ and finally the strip slides between the ordinates $x = 0$ and

$$x = \frac{\pi}{4}.$$

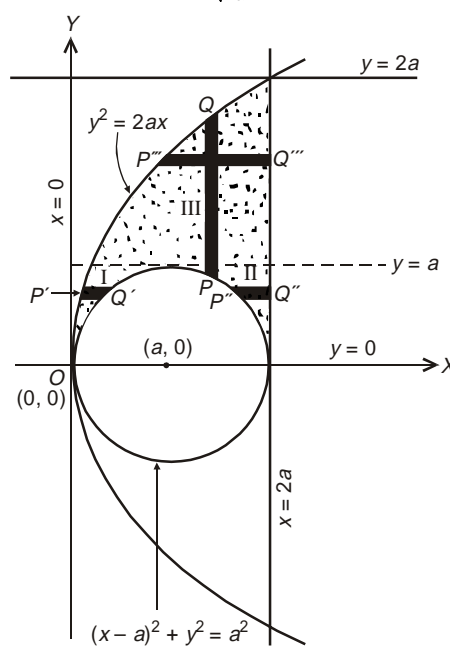

Fig. 5.21

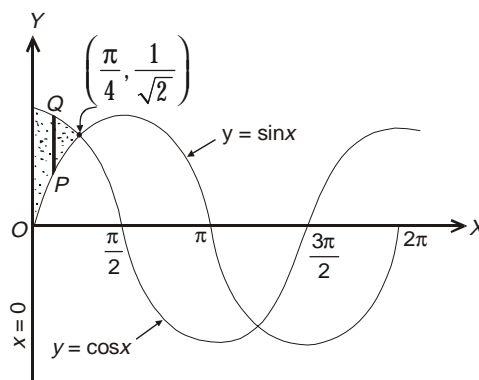

Fig. 5.22

$$\begin{aligned}
 \therefore \iint_R dx dy &= \int_0^{\frac{\pi}{4}} \left(\int_{\sin x}^{\cos x} dy \right) dx \\
 &= \int_0^{\frac{\pi}{4}} (\cos x - \sin x) dx \\
 &= (\sin x + \cos x)_0^{\pi/4} \\
 &= \left(\frac{1}{\sqrt{2}} - 0 \right) + \left(\frac{1}{\sqrt{2}} - 1 \right) \\
 &= (\sqrt{2} - 1)
 \end{aligned}$$

ASSIGNMENT 2

1. Change the order of integration $\int_0^a \int_y^a \frac{x}{x^2 + y^2} dx dy$
2. Change the order integration in the integral $\int_{-a}^a \int_0^{\sqrt{a^2 - y^2}} f(x, y) dx dy$
3. Change the order of integration in $\int_0^{a \cos \alpha} \int_{x \tan \alpha}^{\sqrt{a^2 - x^2}} f(x, y) dy dx$
4. Change the order of integration in $\int_0^a \int_{mx}^{lx} f(x, y) dx dy$

[PTU, 2008]

5.4 EVALUATION OF DOUBLE INTEGRAL IN POLAR COORDINATES

To evaluate $\int_{\theta=\alpha}^{\theta=\beta} \int_{r=\phi(\theta)}^{r=\psi(\theta)} f(r, \theta) dr d\theta$, we first integrate with respect to r between the limits

$r = \phi(\theta)$ to $r = \psi(\theta)$ keeping θ as a constant and then the resulting expression is integrated with respect to θ from $\theta = \alpha$ to $\theta = \beta$.

Geometrical Illustration: Let AB and CD be the two continuous curves $r = \phi(\theta)$ and $r = \psi(\theta)$ bounded between the lines $\theta = \alpha$ and $\theta = \beta$ so that $ABDC$ is the required region of integration.

Let PQ be a radial strip of angular thickness $\delta\theta$ when OP makes an angle θ with the initial line.

Here $\int_{r=\phi(\theta)}^{r=\psi(\theta)} f(r, \theta) dr$ refers to the integration with respect to r along the radial strip PQ and then integration with respect to θ means rotation of this strip PQ from AC to CD .

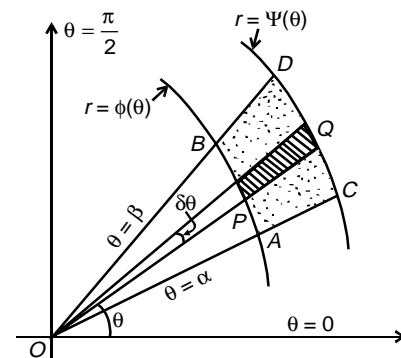

Fig. 5.23

Example 18: Evaluate $\iint r \sin \theta \, dr \, d\theta$ over the cardioid $r = a(1 - \cos \theta)$ above the initial line.

Solution: The region of integration under consideration is the cardioid $r = a(1 - \cos \theta)$ above the initial line.

$$\text{In the cardioid } r = a(1 - \cos \theta); \text{ for } \left. \begin{array}{l} \theta = 0, \quad r = 0, \\ \theta = \frac{\pi}{2}, \quad r = a, \\ \theta = \pi, \quad r = 2a \end{array} \right\}$$

As clear from the geometry along the radial strip OP , r (as a function of θ) varies from $r = 0$ to $r = a(1 - \cos \theta)$ and then this strip slides from $\theta = 0$ to $\theta = \pi$ for covering the area above the initial line.

Hence

$$\begin{aligned} I &= \int_0^\pi \left(\int_0^{r=a(1-\cos\theta)} r \, dr \right) \sin \theta \, d\theta \\ &= \int_0^\pi \left(\frac{r^2}{2} \Big|_0^{a(1-\cos\theta)} \right) \sin \theta \, d\theta \\ &= \frac{a^2}{2} \int_0^\pi (1 - \cos \theta)^2 \sin \theta \, d\theta \\ &= \frac{a^2}{2} \left[\frac{(1 - \cos \theta)^3}{3} \right]_0^\pi, \quad \left[\because \int f^n(x) f'(x) \, dx = \frac{f^{n+1}(x)}{n+1} \right] \\ &= \frac{a^2}{6} [(1 - \cos \pi)^3 - (1 - \cos 0)] = \frac{a^2}{6} [8 - 0] = \frac{4a^2}{3}. \end{aligned}$$

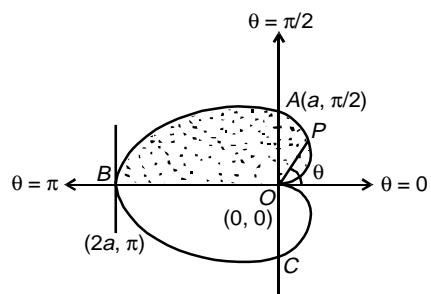

Fig. 5.24

Example 19: Show that $\iint_R r^2 \sin \theta \, dr \, d\theta = \frac{2a^3}{3}$, where R is the semi-circle $r = 2a \cos \theta$ above the initial line.

Solution: The region R of integration is the semi-circle $r = 2a \cos \theta$ above the initial line.

$$\text{For the circle } \left. \begin{array}{l} r = 2a \cos \theta, \theta = 0 \Rightarrow r = 2a \\ \theta = \frac{\pi}{2} \Rightarrow r = 0 \end{array} \right\}$$

$$\begin{aligned} \text{Otherwise also, } r = 2a \cos \theta &\Rightarrow r^2 = 2ar \cos \theta \\ x^2 + y^2 &= 2ax \\ (x^2 - 2ax + a^2) + y^2 &= a^2 \\ (x - a)^2 + (y - 0)^2 &= a^2 \end{aligned}$$

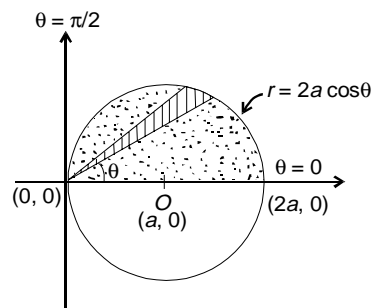

Fig. 5.25

i.e., it is the circle with centre $(a, 0)$ and radius $r = a$

$$\begin{aligned}
 \text{Hence the desired area} &= \int_0^{\frac{\pi}{2}} \int_0^{2a\cos\theta} r^2 \sin\theta \, dr \, d\theta \\
 &= \int_0^{\frac{\pi}{2}} \left(\int_0^{2a\cos\theta} r^2 \, dr \right) \sin\theta \, d\theta \\
 &= \int_0^{\pi/2} \left(\left[\frac{r^3}{3} \right]_0^{2a\cos\theta} \right) \sin\theta \, d\theta \\
 &= \frac{-1}{3} \int_0^{\pi/2} (2a)^3 \cos^3\theta \sin\theta \, d\theta \\
 &= \frac{-8a^3}{3} \left(\frac{\cos^4\theta}{4} \right)_0^{\pi/2}, \quad \text{using } \int f(x) f'(x) dx = \frac{f(x)^{n+1}}{n+1} \\
 &= \frac{2a^3}{3}.
 \end{aligned}$$

Example 20: Evaluate $\iint \frac{r \, dr \, d\theta}{\sqrt{a^2 + r^2}}$ over one loop of the lemniscate $r^2 = a^2 \cos 2\theta$.

[KUK, 2000; MDU, 2006]

Solution: The lemniscate is bounded for $r = 0$ implying $\theta = \pm \frac{\pi}{4}$ and maximum value of r is a .

See Fig. 5.26, in one complete loop, r varies from 0 to $r = a\sqrt{\cos 2\theta}$ and the radial strip slides between $\theta = -\frac{\pi}{4}$ to $\frac{\pi}{4}$.

Hence the desired area

$$\begin{aligned}
 A &= \int_{-\pi/4}^{\pi/4} \int_0^{a\sqrt{\cos 2\theta}} \frac{r}{(a^2 + r^2)^{1/2}} \, dr \, d\theta \\
 &= \int_{-\pi/4}^{\pi/4} \left(\int_0^{a\sqrt{\cos 2\theta}} d(a^2 + r^2)^{1/2} \, dr \right) d\theta \\
 &= \int_{-\pi/4}^{\pi/4} (a^2 + r^2)^{1/2} \Big|_0^{a\sqrt{\cos 2\theta}} \, d\theta \\
 &= \int_{-\pi/4}^{\pi/4} \left[(a^2 + a^2 \cos 2\theta)^{1/2} - a \right] d\theta \\
 &= a \int_{-\pi/4}^{\pi/4} (\sqrt{2} \cos\theta - 1) \, d\theta
 \end{aligned}$$

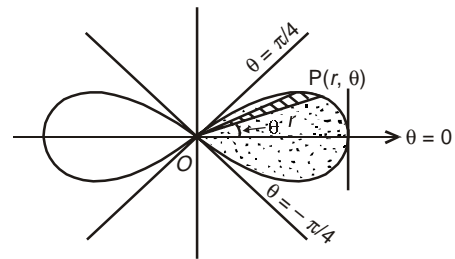

Fig. 5.26

$$\begin{aligned}
 &= 2a \int_0^{\pi/4} (\sqrt{2} \cos \theta - 1) d\theta \\
 &= 2a \left[(\sqrt{2} \sin \theta - \theta)_0^{\pi/4} \right] \\
 &= 2a \left[\sqrt{2} \frac{1}{\sqrt{2}} - \frac{\pi}{4} \right] = 2a \left(1 - \frac{\pi}{4} \right).
 \end{aligned}$$

Example 21: Evaluate $\iint r^3 dr d\theta$, over the area included between the circles $r = 2a \cos \theta$ and $r = 2b \cos \theta$ ($b < a$). [KUK, 2004]

Solution: Given $r = 2a \cos \theta$ or $r^2 = 2ar \cos \theta$

$$x^2 + y^2 = 2ax$$

$$(x + a)^2 + (y - 0)^2 = a^2$$

i.e this curve represents the circle with centre $(a, 0)$ and radius a .

Likewise, $r = 2b \cos \theta$ represents the circle with centre $(b, 0)$ and radius b .

We need to calculate the area bounded between the two circles, where over the radial

strip PQ , r varies from circle $r = 2b \cos \theta$ to $r = 2a \cos \theta$ and finally θ varies from $-\frac{\pi}{2}$ to $\frac{\pi}{2}$.

$$\begin{aligned}
 \text{Thus, the given integral } \iint_R r^3 dr d\theta &= \int_{-\pi/2}^{\pi/2} \int_{2b \cos \theta}^{2a \cos \theta} r^3 dr d\theta \\
 &= \int_{-\pi/2}^{\pi/2} \left[\frac{r^4}{4} \right]_{2b \cos \theta}^{2a \cos \theta} d\theta \\
 &= \frac{1}{4} \int_{-\pi/2}^{\pi/2} [(2a \cos \theta)^4 - (2b \cos \theta)^4] d\theta \\
 &= 4(a^4 - b^4) \int_{-\pi/2}^{\pi/2} \cos^4 \theta d\theta \\
 &= 8(a^4 - b^4) \int_0^{\pi/2} \cos^4 \theta d\theta \\
 &= 8(a^4 - b^4) \frac{3 \cdot 1 \pi}{4 \cdot 2 \cdot 2} \\
 &= \frac{3}{2} \pi (a^4 - b^4).
 \end{aligned}$$

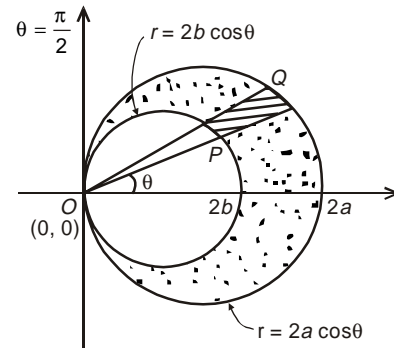

Fig 5. 27

Particular Case: When $r = 2 \cos \theta$ and $r = 4 \cos \theta$ i.e., $a = 2$ and $b = 1$, then

$$I = \frac{3}{2} \pi (a^4 - b^4) = \frac{3}{2} \pi (2^4 - 1^4) = \frac{45\pi}{2} \text{ units.}$$

ASSIGNMENT 3

1. Evaluate $\iint r \sin \theta \, dr \, d\theta$ over the area of the cardioid $r = a(1 + \cos \theta)$ above the initial line.

$$\left[\text{Hint : } I = \int_0^\pi \int_0^{a(1+\cos\theta)} r \sin \theta \, dr \, d\theta \right]$$

2. Evaluate $\iint r^3 \, dr \, d\theta$, over the area included between the circles $r = 2a \cos \theta$ and $r = 2b \cos \theta$ ($b > a$). [Madras, 2006]

$$\left[\text{Hint : } I = \int_{-\pi/2}^{\pi/2} \left(\int_{r=2a \cos \theta}^{r=2b \cos \theta} r^3 \, dr \right) d\theta \right] \text{ (See Fig. 5.27 with } a \text{ and } b \text{ interchanged)}$$

3. Find by double integration, the area lying inside the cardioid $r = a(1 + \cos \theta)$ and outside the parabola $r(1 + \cos \theta) = a$. [NIT Kurukshetra, 2008]

$$\left[\text{Hint : } 2 \int_0^{\pi/2} \left(\int_{\frac{a}{1+\cos\theta}}^{a(1+\cos\theta)} r \, dr \right) d\theta \right]$$

5.5 CHANGE OF ORDER OF INTERGRATION IN DOUBLE INTEGRAL IN POLAR COORDINATES

In the integral $\int_{\theta=\alpha}^{\theta=\beta} \int_{r=\phi(\theta)}^{r=\psi(\theta)} f(r, \theta) \, dr \, d\theta$, iteration is first performed with respect to r along a 'radial strip' and then this strip slides between two values of $\theta = \alpha$ to $\theta = \beta$.

In the changed order, integration is first performed with respect to θ (as a function of r) along a 'circular arc' keeping r constant and then integrate the resulting integral with respect to r between two values $r = a$ to $r = b$ (say)

Mathematically expressed as

$$\int_{\theta=\alpha}^{\theta=\beta} \int_{r=\phi(\theta)}^{r=\psi(\theta)} f(r, \theta) \, dr \, d\theta = I = \int_{r=a}^{r=b} \int_{\theta=f_1(r)}^{\theta=f_2(r)} f(r, \theta) \, d\theta \, dr$$

Example 22: Change the order of integration in the integral $\int_0^{\pi/2} \int_0^{2a \cos \theta} f(r, \theta) \, dr \, d\theta$

Solution: Here, integration is first performed with respect to r (as a function of θ) along a **radial strip** OP (say) from $r = 0$ to $r = 2a \cos \theta$ and finally this

radial strip slides between $\theta = 0$ to $\theta = \frac{\pi}{2}$.

Curve $r = 2a \cos \theta \Rightarrow r^2 = 2a r \cos \theta$
 $\Rightarrow x^2 + y^2 = 2ax \Rightarrow (x - a)^2 + y^2 = a^2$
i.e., it is circle with centre $(a, 0)$ and radius a .

On changing the order of integration, we have to first integrate with respect to θ (as a function of r) along

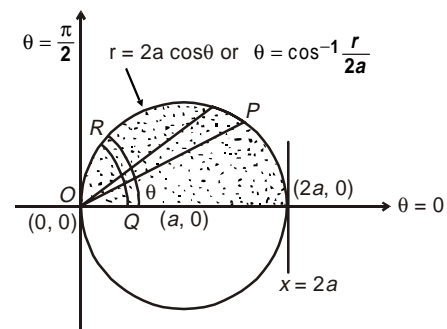

Fig. 5.28

the 'circular strip' QR (say) with pt. Q on the curve $\theta = 0$ and pt. R on the curve $\theta = \cos^{-1} \frac{r}{2a}$ and finally r varies from 0 to $2a$.

$$\therefore I = \int_0^{\frac{\pi}{2}} \int_0^{2a \cos \theta} f(r, \theta) dr d\theta = 2a \left(\int_0^{\cos^{-1} \frac{r}{2a}} \int_0^r f(r, \theta) d\theta \right) dr$$

Example 23: Sketch the region of integration $\int_a^{ae^{\pi/4}} \int_{2 \log \frac{r}{a}}^{\pi/2} f(r, \theta) r dr d\theta$ and change the order of integration.

Solution: Double integral $\int_0^{ae^{\pi/4}} \int_{2 \log \frac{r}{a}}^{\pi/2} f(r, \theta) r dr d\theta$ is identical to $\int_{r=\alpha}^{r=\beta} \int_{\theta=f_1(r)}^{\theta=f_2(r)} f(r, \theta) r dr d\theta$, whence integration is first performed with respect to θ as a function of r i.e., $\theta = f(r)$ along the 'circular strip' PQ (say) with point P on the curve $\theta = 2 \log \frac{r}{a}$ and point Q on the curve $\theta = \frac{\pi}{2}$ and finally this strip slides between between $r = a$ to $r = ae^{\pi/4}$. (See Fig. 5.29).

The curve $\theta = 2 \log \frac{r}{a}$ implies $\frac{\theta}{2} = \log \frac{r}{a}$

$$e^{\theta/2} = \frac{r}{a} \quad \text{or} \quad r = ae^{\theta/2}$$

Now on changing the order, the integration is first performed with respect to r as a function of θ viz. $r = f(\theta)$ along the 'radial strip' PQ (say) and finally this strip slides between $\theta = 0$ to $\theta = \frac{\pi}{2}$. (Fig. 5.30).

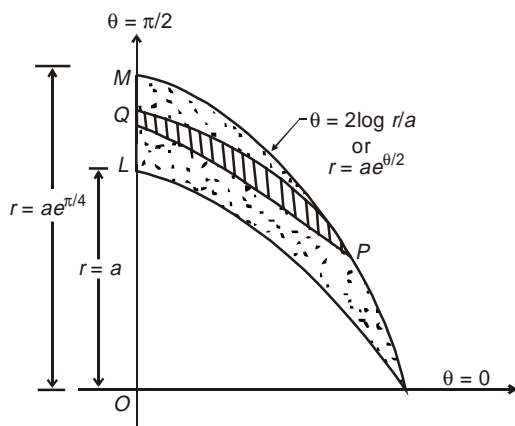

Fig. 5.29

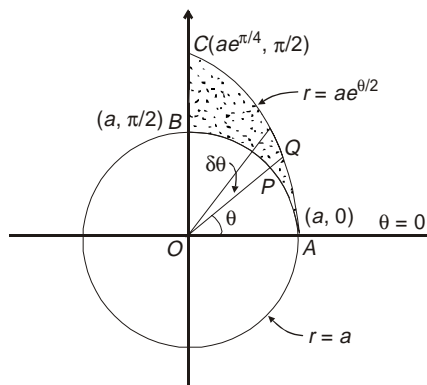

Fig. 5.30

$$\therefore I = \int_{\theta=0}^{\pi/2} \left(\int_{r=a}^{r=ae^{\theta/2}} f(r, \theta) r dr \right) d\theta$$

5.6. AREA ENCLOSED BY PLANE CURVES

1. Cartesian Coordinates: Consider the area bounded by the two continuous curves $y = \phi(x)$ and $y = \Psi(x)$ and the two ordinates $x = a$, $x = b$ (Fig. 5.31).

Now divide this area into vertical strips each of width δx .

Let $R(x, y)$ and $S(x + \delta x, y + \delta y)$ be the two neighbouring points, then the area of the elementary shaded portion (i.e., small rectangle) = $\delta x \delta y$

But all the such small rectangles on this strip PQ are of the same width δx and y changes as a function of x from $y = \phi(x)$ to $y = \Psi(x)$

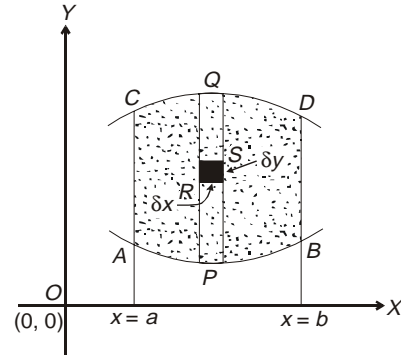

Fig. 5.31

$$\therefore \text{The area of the strip } PQ = \lim_{\delta y \rightarrow 0} \sum \delta x \delta y = \delta x \lim_{\delta y \rightarrow 0} \sum_{\phi(x)}^{\Psi(x)} dy = \delta x \int_{\phi(x)}^{\Psi(x)} dy$$

Now on adding such strips from $x = a$, we get the desired area $ABCD$,

$$\lim_{\delta y \rightarrow 0} \sum_{\phi(x)}^{\Psi(x)} \delta x \int_{\phi(x)}^{\Psi(x)} dy = \int_a^b dx \int_{\phi(x)}^{\Psi(x)} dy = \int_a^b \int_{\phi(x)}^{\Psi(x)} dx dy$$

Likewise taking horizontal strip $P'Q'$ (say) as shown, the area $ABCD$ is given by

$$\int_{y=a}^{y=b} \int_{x=\phi(y)}^{x=\Psi(y)} dx dy$$

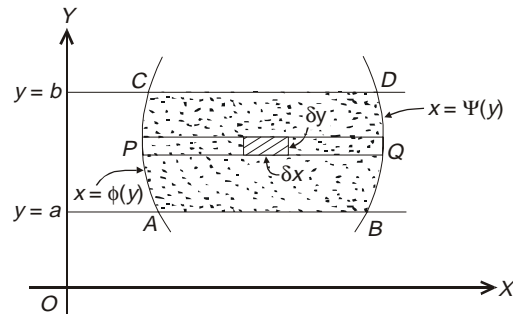

Fig. 5.32

2 Polar Coordinates: Let R be the region enclosed by a polar curve with $P(r, \theta)$ and $Q(r + \delta r, \theta + \delta \theta)$ as two neighbouring points in it.

Let $PP'Q'Q'$ be the circular area with radii OP and OQ equal to r and $r + \delta r$ respectively.

Here the area of the curvilinear rectangle is approximately

$$= PP' \cdot PQ' = \delta r \cdot r \sin \delta \theta = \delta r \cdot r \delta \theta = r \delta r \delta \theta.$$

If the whole region R is divided into such small curvilinear rectangles then the limit of the sum $\sum r \delta r \delta \theta$ taken over R is the area A enclosed by the curve.

i.e.,
$$A = \lim_{\substack{\delta r \rightarrow 0 \\ \delta \theta \rightarrow 0}} \sum r \delta r \delta \theta = \iint_R r dr d\theta$$

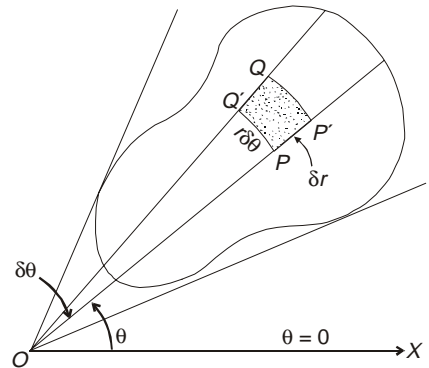

Fig. 5.33

Example 24: Find by double integration, the area lying between the curves $y = 2 - x^2$ and $y = x$.

Solution: The given curve $y = 2 - x^2$ is a parabola.

where in

$$\left. \begin{aligned} x=0 &\Rightarrow y=0 \\ x=1 &\Rightarrow y=1 \\ x=2 &\Rightarrow y=-2 \\ x=-1 &\Rightarrow y=1 \\ x=-2 &\Rightarrow y=-2 \end{aligned} \right\}$$

i.e., it passes through points (0, 2), (1, 1), (2, -2), (-1, 1), (-2, -2).

Likewise, the curve $y = x$ is a straight line

where

$$\left. \begin{aligned} y=0 &\Rightarrow x=0 \\ y=1 &\Rightarrow x=1 \\ y=-2 &\Rightarrow x=-2 \end{aligned} \right\}$$

i.e., it passes through (0, 0), (1, 1), (-2, -2)

Now for the two curves $y = x$ and $y = 2 - x^2$ to intersect, $x = 2 - x^2$ or $x^2 + x - 2 = 0$ i.e., $x = 1, -2$ which in turn implies $y = 1, -2$ respectively.

Thus, the two curves intersect at (1, 1) and (-2, -2).

Clearly, the area need to be required is ABCDA.

$$\begin{aligned} \therefore A &= \int_{-2}^1 \left(\int_x^{2-x^2} dy \right) dx = \int_{-2}^1 (2 - x^2 - x) dx \\ &= \left[2x - \frac{x^3}{3} - \frac{x^2}{2} \right]_{-2}^1 = \frac{9}{2} \text{ units.} \end{aligned}$$

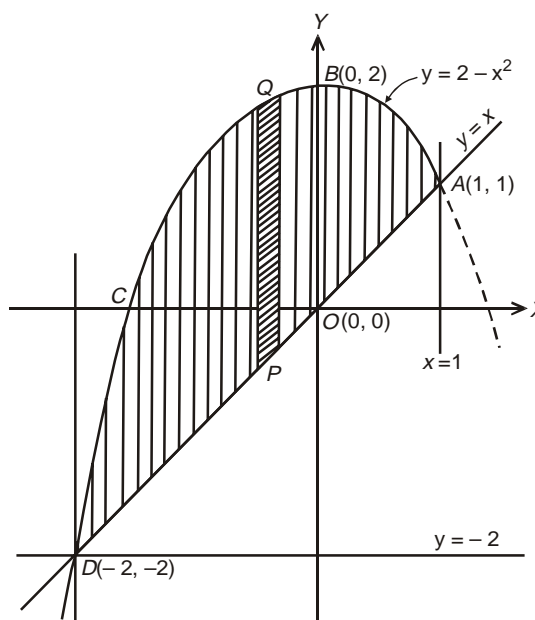

Fig. 5.34

Example 25: Find by double integration, the area lying between the parabola $y = 4x - x^2$ and the line $y = x$. [KUK, 2001]

Solution: For the given curve $y = 4x - x^2$;

$$\left. \begin{aligned} x=0 &\Rightarrow y=0 \\ x=1 &\Rightarrow y=2 \\ x=2 &\Rightarrow y=4 \\ x=3 &\Rightarrow y=3 \\ x=4 &\Rightarrow y=0 \end{aligned} \right\}$$

i.e. it passes through the points (0, 0), (1, 2), (3, 3) and (4, 0).

Likewise, the curve $y = x$ passes through (0, 0) and (3, 3), and hence, (0, 0) and (3, 3) are the common points.

Otherwise also putting $y = x$ into $y = 4x - x^2$, we get $x = 4x - x^2 \Rightarrow x = 0, 3$.

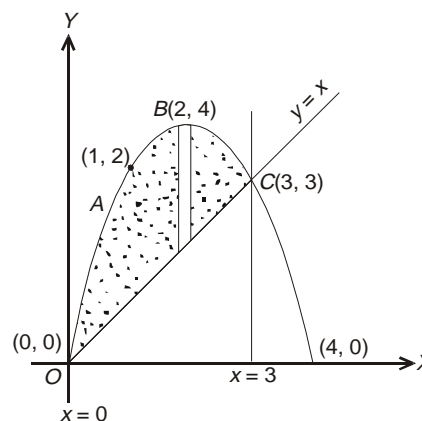

Fig. 5.35

See Fig. 5.35, $OABCO$ is the area bounded by the two curves $y = x$ and $y = 4x - x^2$

$$\begin{aligned} \therefore \text{Area } OABCO &= \int_0^3 \int_x^{4x-x^2} dy dx \\ &= \int_0^3 [y]_x^{4x-x^2} dx \\ &= \int_0^3 (4x - x^2 - x) dx = \left[3 \frac{x^2}{2} - \frac{x^3}{3} \right]_0^3 = \frac{9}{2} \text{ units} \end{aligned}$$

Example 26: Calculate the area of the region bounded by the curves $y = \frac{3x}{x^2 + 2}$ and $4y = x^2$
[JNTU, 2005]

Solution: The curve $4y = x^2$ is a parabola

where $\left. \begin{array}{l} y = 0 \Rightarrow x = 0, \\ y = 1 \Rightarrow x = \pm 2 \end{array} \right\}$ i.e., it passes through $(-2, 1)$, $(0, 0)$, $(2, 1)$.

Likewise, for the curve $y = \frac{3x}{x^2 + 2}$

$$\left. \begin{array}{l} y = 0 \Rightarrow x = 0 \\ y = 1 \Rightarrow x = 1, 2 \\ x = -1 \Rightarrow y = -1 \end{array} \right\}$$

Hence it passes through points $(0, 0)$, $(1, 1)$, $(2, 1)$, $(-1, -1)$.

Also for the curve $(x^2 + 2)y = 3x$, $y = 0$ (i.e. X -axis) is an asymptote.

For the points of intersection of the two curves $y = \frac{3x}{x^2 + 2}$ and $4y = x^2$

we write $\frac{3x}{x^2 + 2} = \frac{x^2}{4}$ or $x^2(x^2 + 2) = 12x$

Then $x = 0 \Rightarrow y = 0$

$$x = 2 \Rightarrow y = 1$$

i.e. $(0, 0)$ and $(2, 1)$ are the two points of intersection.

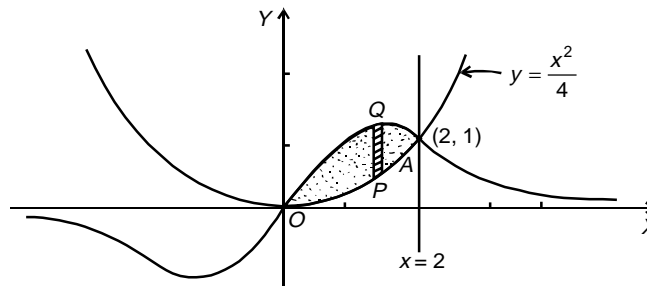

Fig. 5.36

The area under consideration,

$$\begin{aligned} A &= \int_0^2 \left(\int_{y=\frac{x^2}{4}}^{y=\frac{3x}{x^2+2}} dy \right) dx = \int_0^2 \left[\frac{3x}{x^2+2} - \frac{x^2}{4} \right] dx \\ &= \left[\frac{3}{2} \log(x^2+2) - \frac{x^3}{12} \right]_0^2 \\ &= \frac{3}{2} (\log 6 - \log 2) - \frac{2}{3} = \log 3^{\frac{3}{2}} - \frac{2}{3}. \end{aligned}$$

Example 27: Find by the double integration, the area lying inside the circle $r = a \sin \theta$ and outside the cardioid $r = a(1 - \cos \theta)$. [KUK 2005; NIT Kurukshetra 2007]

Soluton: The area enclosed inside the circle $r = a \sin \theta$ and the cardioid $r = a(1 - \cos \theta)$ is shown as dotted one.

For the radial strip PQ , r varies from $r = a(1 - \cos \theta)$ to $r = a \sin \theta$ and finally θ varies in between 0 to $\frac{\pi}{2}$.

For the circle $r = a \sin \theta$

$$\left. \begin{aligned} \theta = 0 &\Rightarrow r = 0 \\ \theta = \frac{\pi}{2} &\Rightarrow r = a \\ \theta = \pi &\Rightarrow r = 0 \end{aligned} \right\}$$

Likewise for the cardioid $r = a(1 - \cos \theta)$;

$$\left. \begin{aligned} \theta = 0 &\Rightarrow r = 0 \\ \theta = \frac{\pi}{2} &\Rightarrow r = a \\ \theta = \pi &\Rightarrow r = 2a \end{aligned} \right\}$$

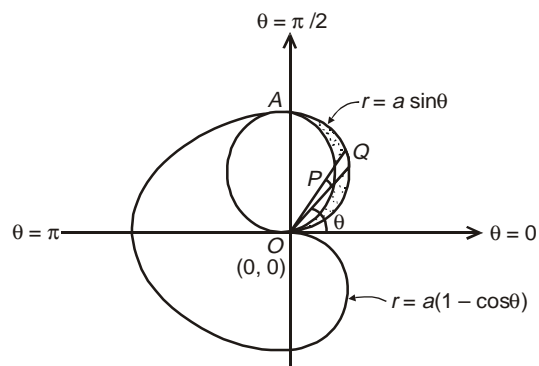

Fig. 5.37

Thus, the two curves intersect at $\theta = 0$ and $\theta = \frac{\pi}{2}$.

$$\begin{aligned} \therefore A &= \int_0^{\frac{\pi}{2}} \int_{a(1-\cos\theta)}^{a\sin\theta} r dr d\theta \\ &= \int_0^{\pi/2} \frac{r^2}{2} \Big|_{a(1-\cos\theta)}^{a\sin\theta} d\theta \\ &= \int_0^{\pi/2} \frac{1}{2} [\sin^2 \theta - (1 + \cos^2 \theta - 2 \cos \theta)] d\theta \\ &= \frac{a^2}{2} \int_0^{\pi/2} [-\cos 2\theta - 1 + 2 \cos \theta] d\theta, \text{ since } (\sin^2 \theta - \cos^2 \theta) = -\cos 2\theta \end{aligned}$$

$$= \frac{a^2}{2} \left[\frac{-\sin 2\theta}{2} - \theta + 2 \sin \theta \right]_0^{\pi/2} = a^2 \left(1 - \frac{\pi}{4} \right).$$

Example 28: Calculate the area included between the curve $r = a(\sec\theta + \cos\theta)$ and its asymptote $r = a\sec\theta$. [NIT Kurukshetra, 2007]

Solution: As the given curve $r = a(\sec\theta + \cos\theta)$ i.e., $r = a\left(\frac{1}{\cos\theta} + \cos\theta\right)$ contains cosine terms only and hence it is symmetrical about the initial axis.

Further, for $\theta = 0$, $r = 2a$ and, r goes on decreasing above and below the initial axis as θ approaches to $\frac{\pi}{2}$ and at $\theta = \frac{\pi}{2}$, $r = \infty$.

Clearly, the required area is the dotted region in which r varies along the radial strip from $r = a\sec\theta$ to $r = a(\sec\theta + \cos\theta)$ and finally strip slides between $\theta = -\frac{\pi}{2}$ to $\theta = \frac{\pi}{2}$.

$$\begin{aligned} \therefore A &= 2 \int_0^{\pi/2} \int_{a\sec\theta}^{a(\sec\theta + \cos\theta)} r \, dr \, d\theta \\ &= 2 \int_0^{\pi/2} \left[\frac{r^2}{2} \right]_{a\sec\theta}^{a(\sec\theta + \cos\theta)} d\theta \\ &= a^2 \int_0^{\pi/2} \left[\left(\frac{1 + \cos^2 \theta}{\cos \theta} \right)^2 - \left(\frac{1}{\cos \theta} \right)^2 \right] d\theta \\ &= a^2 \int_0^{\pi/2} (\cos^2 \theta + 2) d\theta \\ &= a^2 \int_0^{\pi/2} \frac{(5 + \cos 2\theta)}{2} d\theta \\ &= \frac{a^2}{2} \left[5\theta + \frac{\sin 2\theta}{2} \right]_0^{\pi/2} = \frac{5\pi a^2}{4}. \end{aligned}$$

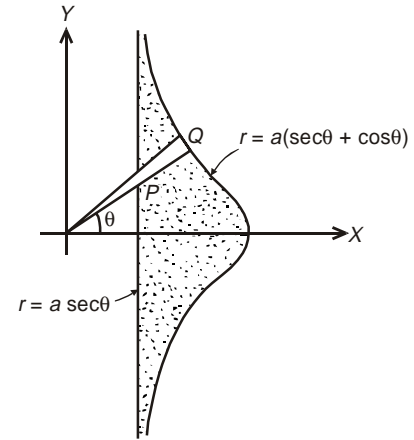

Fig. 5.38

ASSIGNMENT 4

1. Show by double integration, the area bounded between the parabola $y^2 = 4ax$ and $x^2 = 4ay$ is $\frac{16}{3} a^2$. [MDU, 2003; NIT Kurukshetra, 2010]
2. Using double integration, find the area enclosed by the curves, $y^2 = x^3$ and $y = x$. [PTU, 2005]

Example 29: Find by double integration, the area of lamina $r^2 = a^2 \cos 2\theta$.

[Madras, 2000]

Solution: As the given curve $r^2 = a^2 \cos 2\theta$ contains cosine terms only and hence it is symmetrical about the initial axis.

Further the curve lies wholly inside the circle $r = a$, since the maximum value of $|\cos \theta|$ is 1.

Also, no portion of the curve lies between $\theta = \frac{\pi}{4}$ to $\theta = \frac{3\pi}{4}$ and the extended axis.

See the geometry, for one loop, the curve is bounded between $\theta = -\frac{\pi}{4}$ to $\frac{\pi}{4}$

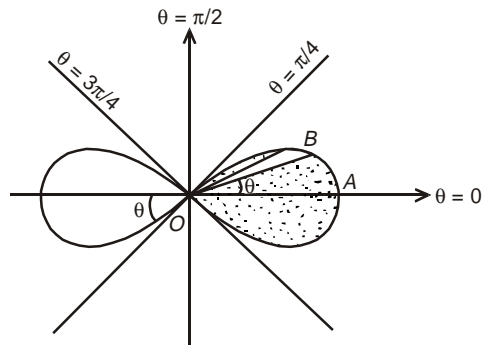

Fig. 5.39

$$\begin{aligned} \therefore \text{Area} &= 2 \int_{-\frac{\pi}{4}}^{\frac{\pi}{4}} \int_{r=0}^{r=\sqrt{a^2 \cos 2\theta}} r dr d\theta \\ &= 4 \int_0^{\pi/4} \frac{r^2}{2} \Big|_0^{a\sqrt{\cos 2\theta}} d\theta \\ &= 2a^2 \int_0^{\pi/4} \cos 2\theta d\theta = 2a^2 \left[\frac{\sin 2\theta}{2} \right]_0^{\pi/4} = a^2 \end{aligned}$$

5.7 CHANGE OF VARIABLE IN DOUBLE INTEGRAL

The concept of change of variable had evolved to facilitate the evaluation of some typical integrals.

Case 1: General change from one set of variable (x, y) to another set of variables (u, v) .

If it is desirable to change the variables in double integral $\iint_R f(x,y) dA$ by making $x = \phi(u, v)$ and $y = \Psi(u, v)$, the expression dA (the elementary area $\delta x \delta y$ in R_{xy}) in terms of u and v is given by

$$dA = \left| J \left(\begin{matrix} x, y \\ u, v \end{matrix} \right) \right| du dv, \quad J \left(\begin{matrix} x, y \\ u, v \end{matrix} \right) \neq 0$$

J is the **Jacobian** (transformation coefficient) or **functional determinant**.

$$\therefore \iint_R f(x,y) dx dy = \iint_R f(u,v) J \left(\begin{matrix} x, y \\ u, v \end{matrix} \right) du dv$$

Case 2: From Cartesian to Polar Coordinates: In transforming to polar coordinates by means of $x = r \cos \theta$ and $y = r \sin \theta$,

$$J \left(\begin{matrix} x, y \\ r, \theta \end{matrix} \right) = \begin{vmatrix} \frac{\partial x}{\partial r} & \frac{\partial x}{\partial \theta} \\ \frac{\partial y}{\partial r} & \frac{\partial y}{\partial \theta} \end{vmatrix} = \begin{vmatrix} \cos \theta & -r \sin \theta \\ \sin \theta & r \cos \theta \end{vmatrix}$$

$$\therefore dA = r dr d\theta \quad \text{and} \quad \iint_R f(x,y) dx dy = \iint_R f(r,\theta) r dr d\theta$$

Example 30: Evaluate $\iint_R (x+y)^2 dx dy$ where R is the parallelogram in the xy plane with vertices $(1, 0)$, $(3, 1)$, $(2, 2)$, $(0, 1)$ using the transformation $u = x + y$, $v = x - 2y$.

[KUK, 2000]

Solution: R_{xy} is the region bounded by the parallelogram $ABCD$ in the xy plane which on transformation becomes R'_{uv} i.e., the region bounded by the rectangle $PQRS$, as shown in the Figs. 5.40 and 5.41 respectively.

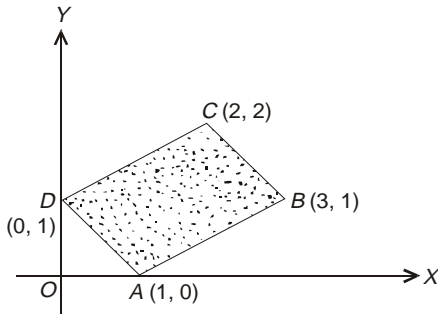

Fig. 5.40

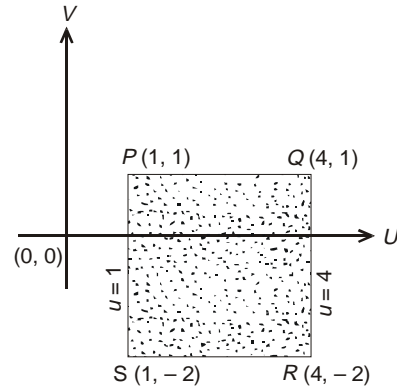

Fig. 5.41

With $\left. \begin{array}{l} u = x + y \\ v = x - 2y \end{array} \right\}$, $A(1, 0)$ transforms to $\left. \begin{array}{l} u = 1 + 0 = 1 \\ v = 1 - 0 = 1 \end{array} \right\}$ i.e., $P(1, 1)$
 $B(3, 1)$ transforms to $Q(4, 1)$
 $C(2, 2)$ transforms to $R(4, -2)$
 $D(0, 1)$ transforms to $S(1, -2)$

and
$$J \frac{\partial(x, y)}{\partial(u, v)} = \begin{vmatrix} \frac{\partial x}{\partial u} & \frac{\partial x}{\partial v} \\ \frac{\partial y}{\partial u} & \frac{\partial y}{\partial v} \end{vmatrix} = -\frac{1}{3}$$

Hence the given integral $\iint_R u^2 \frac{1}{3} du dv$

$$= \int_1^4 \int_{-2}^1 \frac{1}{3} u^2 du dv = \frac{1}{3} \int_1^4 [v]_{-2}^1 u^2 du$$

$$= \frac{1}{3} \times (1 + 2) \int_1^4 u^2 du$$

$$I = \left(\left[\frac{u^3}{3} \right]_1^4 \right) = \frac{63}{3} = 21 \text{ units}$$

Example 31: Using transformation $x + y = u, y = uv$, show that

$$\iint_0^1 \int_0^{1-x} e^{\left(\frac{y}{x+y}\right)} dx dy = \frac{1}{2}(e - 1).$$

[PTU, 2003]

Solution: Clearly $y = f(x)$ represents curves $y = 0$ and $y = 1 - x$, and x which is an independent variable changes from $x = 0$ to $x = 1$. Thus, the area $OABO$ bounded between the two curves $y = 0$ and $x + y = 1$ and the two ordinates $x = 0$ and $x = 1$ is shown in Fig. 5.42.

On using transformation,

$$\begin{aligned} x + y = u &\Rightarrow x = u(1 - v) \\ y = uv &\Rightarrow y = uv \end{aligned}$$

Now point $O(0, 0)$ implies $0 = u(1 - v)$... (1)

and $0 = uv$... (2)

From (2), either $u = 0$ or $v = 0$ or both zero. From (1), we get

$$u = 0, v = 1$$

Hence $(x, y) = (0, 0)$ transforms to $(u, v) = (0, 0), (0, 1)$

Point $A(1, 0)$, implies $1 = u(1 - v)$... (3)

and $0 = uv$... (4)

From (4) either $u = 0$ or $v = 0$. If $v = 0$ then from (3) we have $u = 1$, again if $u = 0$, equation (3) is inconsistent.

Hence, $A(1, 0)$ transforms to $(1, 0)$, i.e. itself.

From Point $B(0, 1)$, we get $0 = u(1 - v)$... (5)

and $1 = uv$... (6)

From (5), either $u = 0$ or $v = 1$

If $u = 0$, equation (6) becomes inconsistent.

If $v = 1$, the equation (6) gives $u = 1$.

Hence $(0, 1)$ transform to $(1, 1)$. See Fig. 5.43.

Hence

$$\begin{aligned} \int_0^1 \int_0^{1-x} e^{\left(\frac{y}{x+y}\right)} dx dy &= \int_0^1 \int_0^1 u e^v du dv \quad \text{where } J = \frac{\partial(x, y)}{\partial(u, v)} = u \\ &= \int_0^1 u \left(\int_0^1 e^v dv \right) du = \int_0^1 u \cdot (e - 1) du = (e - 1) \frac{u^2}{2} \Big|_0^1 = \frac{1}{2}(e - 1) \end{aligned}$$

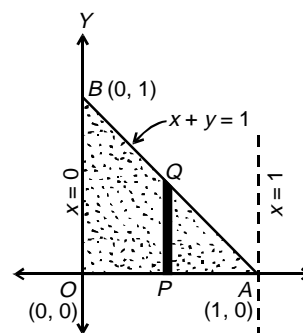

Fig. 5.42

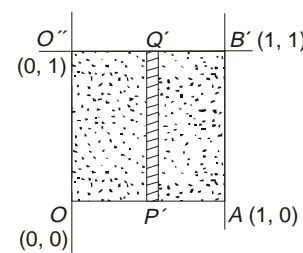

Fig. 5.43

Example 32: Evaluate the integral $\int_0^a \int_{\frac{y^2}{4a}}^{\frac{y}{2}} \frac{x^2 - y^2}{x^2 + y^2} dx dy$ by transforming to polar coordinates.

Solution: Here the curves $x = \frac{y^2}{4a}$ or $y^2 = 4ax$ is parabola passing through $(0, 0)$, $(4a, 4a)$.

Likewise the curve $x = y$ is a straight line passing through points $(0, 0)$ $(4a, 4a)$.

Hence the two curves intersect at $(0, 0)$, $(4a, 4a)$.

In the given form of the integral, x changes (as a function of y) from $x = \frac{y^2}{4a}$ to $x = y$ and finally y as an independent variable varies from $y = 0$ to $y = 4a$.

For transformation to polar coordinates, we take

$$x = r \cos \theta, y = r \sin \theta \text{ and } J = \frac{\partial(x, y)}{\partial(r, \theta)} = r$$

The parabola $y^2 = 4ax$ implies $r^2 \sin^2 \theta = 4ar \cos \theta$ so that r (as a function of θ) varies from $r = 0$ to $r = \frac{4a \cos \theta}{\sin^2 \theta}$ and θ varies from $\theta = \frac{\pi}{4}$ to $\theta = \frac{\pi}{2}$

Therefore, on transformation the integral becomes

$$\begin{aligned} I &= \int_{\pi/4}^{\pi/2} \int_0^{\frac{4a \cos \theta}{\sin^2 \theta}} \frac{r^2 (\cos^2 \theta - \sin^2 \theta)}{r^2} \cdot r \, dr \, d\theta \\ &= \int_{\pi/4}^{\pi/2} \cos 2\theta \cdot \left[\frac{r^2}{2} \right]_0^{\frac{4a \cos \theta}{\sin^2 \theta}} \, d\theta \\ &= \int_{\pi/4}^{\pi/2} (1 - 2 \sin^2 \theta) \frac{16a^2 \cos^2 \theta}{2 \sin^4 \theta} \, d\theta \\ &= 8a^2 \int_{\pi/4}^{\pi/2} \frac{(1 - 2 \sin^2 \theta)(1 - \sin^2 \theta)}{\sin^4 \theta} \, d\theta \\ &= 8a^2 \int_{\pi/4}^{\pi/2} \frac{[1 - 3 \sin^2 \theta + 2 \sin^4 \theta]}{\sin^4 \theta} \, d\theta \\ &= 8a^2 \int_{\pi/4}^{\pi/2} [\operatorname{cosec}^2 \theta (1 + \cot^2 \theta) - 3 \operatorname{cosec}^2 \theta + 2] \, d\theta \\ &= 8a^2 \int_{\pi/4}^{\pi/2} [\cot^2 \theta \operatorname{cosec}^2 \theta - 2 \operatorname{cosec}^2 \theta + 2] \, d\theta \end{aligned}$$

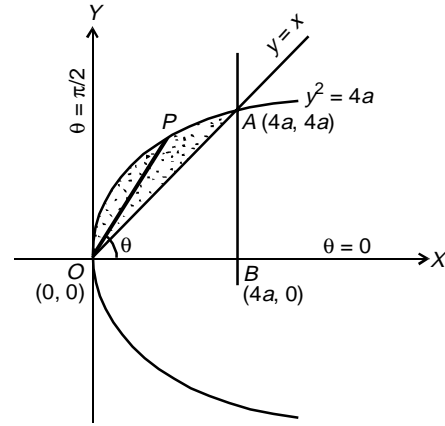

Fig. 5.44

$$= 8a^2 \left[\int_{\pi/4}^{\pi/2} \cot^2 \theta \operatorname{cosec}^2 \theta \, d\theta + 2(\cot \theta)_{\pi/4}^{\pi/2} + (2\theta)_{\pi/4}^{\pi/2} \right]$$

Let $\cot \theta = t$ so that $-\operatorname{cosec}^2 \theta \, d\theta = dt$. Limits for $\theta = \frac{\pi}{4}, t = 1$
 $\theta = \frac{\pi}{2}, t = 0$

$$= 8a^2 \left[\int_1^0 -t^2 dt + 2(0 - 1) + \frac{\pi}{2} \right] = 8a^2 \left[\left| -\frac{t^3}{3} \right|_1^0 - 2 + \frac{\pi}{2} \right]$$

$$= 8a^2 \left(\frac{\pi}{2} - \frac{5}{3} \right).$$

Example 33: Evaluate the integral $\iint_{x/a}^{\sqrt{x/a}} (x^2 + y^2) \, dx dy$ by changing to polar coordinates.

Solution: The above integral has already been discussed under change of order of integration in cartesian co-ordinate system, Example 7.

For transforming any point $P(x, y)$ of cartesian coordinate to polar coordinates $P(r, \theta)$, we

take $x = r \cos \theta, y = r \sin \theta$ and $J = \frac{\partial(x, y)}{\partial(r, \theta)} = r$.

The parabola $y^2 = \frac{x}{a}$ implies $r^2 \sin^2 \theta = \frac{r \cos \theta}{a}$ i.e., $r \left(r \sin^2 \theta - \frac{\cos \theta}{a} \right) = 0$

\Rightarrow either $r = 0$ or $r = \frac{\cos \theta}{a \sin^2 \theta}$

Limits, for the curve $y = \frac{x}{a}$,

$$\theta = \tan^{-1} \frac{y}{x} = \tan^{-1} \frac{BA}{OB} = \tan^{-1} \frac{1}{a}$$

and for the curve $y = \sqrt{\frac{x}{a}}$

$$\theta = \tan^{-1} \frac{0}{a} = \frac{\pi}{2}$$

Here r (as a function of θ) varies from 0 to $\frac{\cos \theta}{a \sin^2 \theta}$

and θ changes from $\tan^{-1} \frac{1}{a}$ to $\frac{\pi}{2}$.

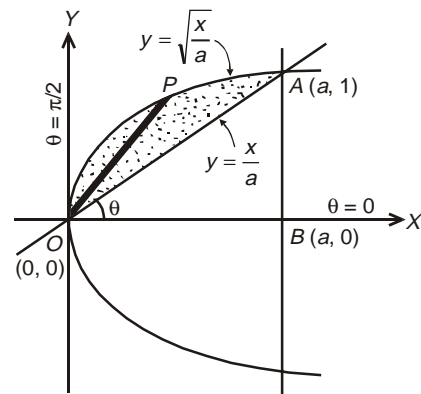

Fig. 5.45

Therefore, the integral,

$$\int_0^a \int_{x/a}^{\sqrt{x/a}} (x^2 + y^2)$$

transforms to.
$$I = \int_{\tan^{-1}\left(\frac{1}{a}\right)}^{\pi/2} \left(\int_0^{\left(\frac{\cos\theta}{a\sin^2\theta}\right)} r^3 dr \right) d\theta$$

$$I = \int_{\cot^{-1}(a)}^{\pi/2} \int_0^{\left(\frac{\cos\theta}{a\sin^2\theta}\right)} r^3 dr d\theta$$

$$= \frac{1}{4} \int_{\cot^{-1}a}^{\pi/2} \frac{\cos^4\theta}{a^4(\sin^4\theta)^2} d\theta$$

$$\Rightarrow I = \frac{1}{4a^4} \int_{\cot^{-1}a}^{\pi/2} \cot^4\theta (1 + \cot^2\theta) \operatorname{cosec}^2\theta d\theta$$

Let $\cot\theta = t$ so that $\operatorname{cosec}^2\theta d\theta = dt(-1)$ and $\theta = \cot^{-1}a \Rightarrow t = a$

$$\left. \begin{aligned} \theta = \frac{\pi}{2} &\Rightarrow t = 0 \end{aligned} \right\}$$

$$\therefore I = \frac{1}{4a^4} \int_a^0 t^4 (1 + t^2) (-dt)$$

$$I = \frac{1}{4a^4} \int_0^a [t^4 + t^6] dt = \frac{1}{4a^4} \left[\frac{t^5}{5} + \frac{t^7}{7} \right]_0^a$$

$$I = \left(\frac{a}{20} + \frac{a^3}{28} \right).$$

Example 34: Evaluate $\int xy(x^2 + y^2)^{\frac{n}{2}} dx dy$ over the positive quadrant of $x^2 + y^2 = 4$, supposing $n + 3 > 0$. [SVTU, 2007]

Solution: The double integral is to be evaluated over the area enclosed by the positive quadrant of the circle $x^2 + y^2 = 4$, whose centre is $(0, 0)$ and radius 2.

Let $x = r\cos\theta$, $y = r\sin\theta$, so that $x^2 + y^2 = r^2$.

Therefore on transformation to polar co-ordinates,

$$I = \int_{\theta=0}^{\theta=\pi/2} \int_{r=0}^{r=2} r \cos\theta r \sin\theta r^n |J| dr d\theta,$$

$$= \int_0^{\pi/2} \int_0^2 (r^{n+3} dr) \sin\theta \cos\theta d\theta, \left(J = \frac{\partial(x, y)}{\partial(r, \theta)} = r \right)$$

$$= \int_0^{\pi/2} \left(\frac{r^{n+4}}{n+4} \right)_0^2 \sin\theta \cos\theta d\theta$$

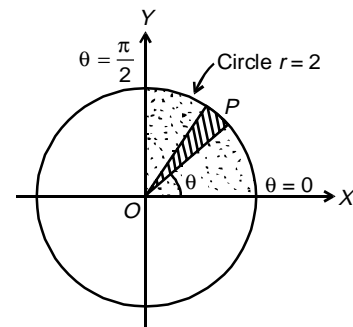

Fig. 5.46

$$\begin{aligned}
 &= \frac{2^{n+4}}{n+4} \int_0^{\frac{\pi}{2}} \sin \theta \cos \theta \, d\theta \\
 &= \frac{2^{n+4}}{(n+4)} \cdot \left| \frac{\sin^2 \theta}{2} \right|_0^{\pi/2}, \text{ using } \int f'(x) f(x) \, dx = \frac{f^2(x)}{2} \\
 &= \frac{2^{n+3}}{(n+4)}, (n+3) > 0.
 \end{aligned}$$

Example 35: Transform to cartesian coordinates and hence evaluate the $\int_0^{\pi} \int_0^a r^3 \sin \theta \cos \theta \, dr \, d\theta$.
 [NIT Kurukshetra, 2007]

Solution: Clearly the region of integration is the area enclosed by the circle $r = 0, r = a$ between $\theta = 0$ to $\theta = \pi$.

Here
$$\begin{aligned}
 I &= \int_0^{\pi} \int_0^a r^3 \sin \theta \cos \theta \, dr \, d\theta \\
 &= \int_0^{\pi} \int_0^a r \sin \theta \cdot r \cos \theta \cdot r \, dr \, d\theta
 \end{aligned}$$

On using transformation $x = r \cos \theta, y = r \sin \theta,$

$$\begin{aligned}
 I &= \int_{-a}^a \int_0^{\sqrt{a^2-x^2}} xy \, dx \, dy \\
 &= \int_{-a}^a x \left(\int_0^{\sqrt{a^2-x^2}} y \, dy \right) dx \\
 &= \int_{-a}^a \left(\frac{y^2}{2} \right) \Big|_0^{\sqrt{a^2-x^2}} x \, dx \\
 &= \frac{1}{2} \int_{-a}^a x(a^2 - x^2) \, dx
 \end{aligned}$$

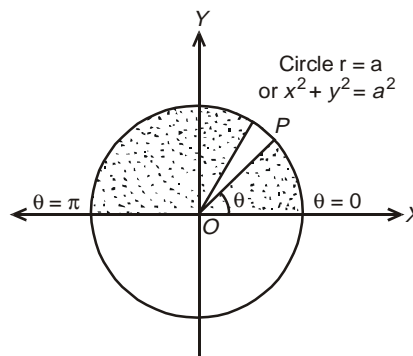

Fig. 5.47

As x and x^3 both are odd functions, therefore net value on integration of the above integral is zero.

i.e.
$$I = \frac{1}{2} \int_{-a}^a (a^2 x - x^3) \, dx = 0.$$

ASSIGNMENTS 5

Evaluate the following integrals by changing to polar coordinates:

- (1) $\int_0^a \int_0^{\sqrt{a^2-y^2}} (x^2 + y^2) \, dx \, dy$ (2) $\int_0^a \int_y^a \frac{x^2}{\sqrt{x^2 + y^2}} \, dx \, dy$

$$(3) \int_{-a}^a \int_{-\sqrt{a^2-x^2}}^{\sqrt{a^2-x^2}} dx dy$$

$$(4) \int_0^{\infty} \int_0^{\infty} e^{-(x^2+y^2)} dx dy$$

[MDU, 2001]

5.8 TRIPLE INTEGRAL (PHYSICAL SIGNIFICANCE)

The triple integral is defined in a manner entirely analogous to the definition of the double integral.

Let $F(x, y, z)$ be a function of three independent variables x, y, z defined at every point in a region of space V bounded by the surface S . Divided V into n elementary volumes $\delta V_1, \delta V_2, \dots, \delta V_n$ and let (x_r, y_r, z_r) be any point inside the r th sub division δV_r . Then, the limit of the sum

$$\sum_{r=1}^n F(x_r, y_r, z_r) \delta V_r, \quad \dots(1)$$

if exists, as $n \rightarrow \infty$ and $\delta V_r \rightarrow 0$ is called the 'triple integral' of $R(x, y, z)$ over the region V , and is denoted by

$$\iiint F(x, y, z) dV \quad \dots(2)$$

In order to express triple integral in the 'integrated' form, V is considered to be subdivided by planes parallel to the three coordinate planes. The volume V may then be considered as the sum of a number of vertical columns extending from the lower surface say, $z = f_1(x, y)$ to the upper surface say, $z = f_2(x, y)$ with base as the elementary areas δA_r over a region R in the xy -plane when all the columns in V are taken.

On summing up the elementary cuboids in the same vertical columns first and then taking the sum for all the columns in V , it becomes

$$\sum_r \left[\sum_r F(x_r, y_r, z_r) \delta z \right] \delta A_r \quad \dots(3)$$

with the pt. (x_r, y_r, z_r) in the r th cuboid over the element δA_r .
When δA_r and δz tend to zero, we can write (3) as

$$\int_R \left[\int_{z=f_1(x,y)}^{z=f_2(x,y)} F(x, y, z) dz \right] dA$$

Note: An ellipsoid, a rectangular parallelepiped and a tetrahedron are regular three dimensional regions.

5.9. EVALUATION OF TRIPLE INTEGRALS

For evaluation purpose, $\iiint_V F(x, y, z) dV$... (1)

is expressed as the repeated integral

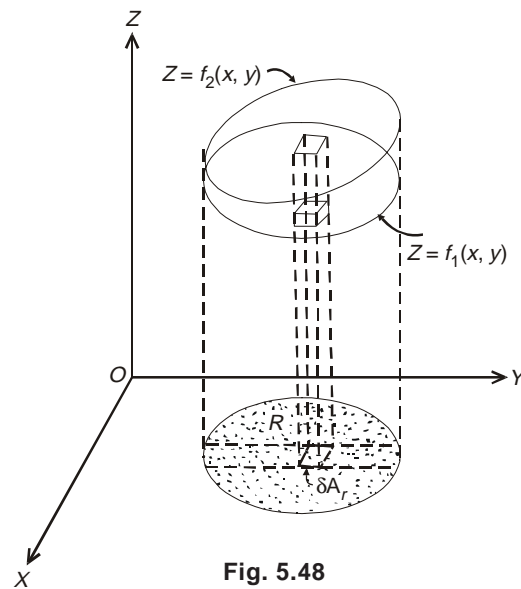

Fig. 5.48

$$\int_{x_1}^{x_2} \int_{y_1}^{y_2} \int_{z_1}^{z_2} F(x, y, z) dz dy dx \quad \dots(2)$$

where in the order of integration depends upon the limits.

If the limits z_1 and z_2 be the functions of (x, y) ; y_1 and y_2 be the functions of x and x_1, x_2 be constant, then

$$I = \int_{x=a}^{x=b} \left(\int_{y=\phi_1(x)}^{y=\phi_2(x)} \left(\int_{z=f_1(x,y)}^{z=f_2(x,y)} F(x, y, z) dz \right) dy \right) dx \quad \dots(3)$$

which shows that the first $F(x, y, z)$ is integrated with respect to z keeping x and y constant between the limits $z = f_1(x, y)$ to $z = f_2(x, y)$. The resultant which is a function of x, y is integrated with respect to y keeping x constant between the limits $y = f_1(x)$ to $y = f_2(x)$. Finally, the integrand is evaluated with respect to x between the limits $x = a$ to $x = b$.

Note: This order can accordingly be changed depending upon the comfort of integration.

Example 36: Evaluate $\int_0^a \int_0^x \int_0^{x+y} e^{x+y+z} dz dy dx$. [KUK, 2000, 2009]

Solution: On integrating first with respect to z , keeping x and y constants, we get

$$\begin{aligned} I &= \int_0^a \int_0^x \left[e^{(x+y)+z} \right]_0^{(x+y)} dy dx, \quad [\text{Here } (x+y) = a, \text{ (say), like some constant}] \\ &= \int_0^a \int_0^x \left[e^{(x+y)+(x+y)} - e^{(x+y)+0} \right] dy dx \\ &= \int_0^a \int_0^x \left[e^{2(x+y)} - e^{(x+y)} \right] dy dx \\ &= \int_0^a \left[\frac{e^{2x+2y}}{2} - \frac{e^{x+y}}{1} \right]_0^x dx, \quad (\text{Integrating with respect to } y, \text{ keeping } x \text{ constant}) \\ &= \int_0^a \left[\left(\frac{e^{4x}}{2} - \frac{e^{2x}}{1} \right) - \left(\frac{e^{2x}}{2} - \frac{e^x}{1} \right) \right] dx \end{aligned}$$

On integrating with respect to x ,

$$\begin{aligned} &= \left[\frac{e^{4x}}{8} - \frac{e^{2x}}{2} - \frac{e^{2x}}{4} + \frac{e^x}{1} \right]_0^a \\ &= \left(\frac{e^{4a}}{8} - \frac{e^{2a}}{2} - \frac{e^{2a}}{4} + e^a \right) - \left(\frac{1}{8} - \frac{1}{2} - \frac{1}{4} + 1 \right) \\ \Rightarrow I &= \left(\frac{e^{4a}}{8} - \frac{3}{4} e^{2a} + e^a - \frac{3}{8} \right). \end{aligned}$$

Example 37: Evaluate $\int_0^{\pi/2} \int_0^{\sin\theta} \int_0^{\frac{a^2-r^2}{a}} r dr d\theta dz$. [VTU, 2007; NIT Kurukshetra, 2007, 2010]

Solution: On integrating with respect to z first keeping r and θ constants, we get

$$\begin{aligned}
 I &= \int_0^{\pi/2} \int_0^{a \sin \theta} (z)_0^{\frac{a^2-r^2}{a}} r dr d\theta \\
 &= \frac{1}{a} \int_0^{\pi/2} \int_0^{a \sin \theta} (a^2 - r^2) r dr d\theta \\
 &= \frac{1}{a} \int_0^{\pi/2} \left(a^2 \frac{r^2}{2} - \frac{r^4}{4} \right)_0^{a \sin \theta} d\theta, \quad (\text{On integrating with respect to } r) \\
 &= \frac{1}{a} \int_0^{\pi/2} \left(\frac{a^2 \cdot a^2 \sin^2 \theta}{2} - \frac{a^4 \sin^4 \theta}{4} \right) d\theta \\
 &= \frac{a^3}{4} \int_0^{\pi/2} [2 \sin^2 \theta - \sin^4 \theta] d\theta \\
 &= \frac{a^3}{4} \left[2 \cdot \frac{1}{2} \cdot \frac{\pi}{2} - \frac{3 \cdot 1}{4 \cdot 2} \cdot \frac{\pi}{2} \right],
 \end{aligned}$$

$$\int_0^{\pi/2} \sin^p x dx = \frac{(p-1) \cdot (p-3) \dots}{(p) \cdot (p-2) \dots} \times \left(\frac{\pi}{2}; \text{only if } p \text{ is even} \right)$$

$$\therefore I = \frac{a^3}{4} \left[\frac{\pi}{2} \left(1 - \frac{3}{8} \right) \right] = \frac{5\pi a^3}{64}$$

Example 38: Evaluate $\iiint_1^{e^x} \int_1^{e^{xy}} \log z dz dy dx$.

[MDU, 2005; KUK, 2004, 05]

Solution: $\int_1^e \int_0^{\log y} \left(\int_1^{e^x} \log z dz \right) dx dy$

[Here $z = f(x, y)$ with $z_1 = 1$ and $z_2 = e^{x+0y}$

$$\begin{aligned}
 &= \int_1^e \int_0^{\log y} \left(\int_1^{e^x} \log z \cdot 1 \right) dz dx dy \\
 &\quad \text{Ist fun.} \quad \text{IInd fun.} \\
 &= \int_1^e \int_0^{\log y} \left[\log z \times z - \int z \frac{1}{z} dz \right]_1^{e^x} dx dy \\
 &= \int_1^e \int_0^{\log y} \left[(e^x \log e^x - 1 \cdot \log 1) - (z)_1^{e^x} \right] dx dy
 \end{aligned}$$

$$\begin{aligned}
&= \int_1^e \left(\int_0^{\log y} [xe^x - (e^x - 1)] dx \right) dy \\
&= \int_1^e \int_0^{\log y} [(x-1)e^x + 1] dx dy \\
&= \int_1^e [xe^x - 2e^x + x]_0^{\log y} dy \\
&= \int_1^e [(y+1) \cdot \log y + 2(1-y)] dy \\
&\quad \quad \quad \begin{array}{cc} \text{I} & \text{II} \\ \text{function} & \text{function} \end{array}
\end{aligned}$$

On integrating by parts,

$$\begin{aligned}
I &= \left[\log y \times \left(\frac{y^2}{2} + y \right) \Big|_1^e - \int_1^e \frac{1}{y} \cdot \left(\frac{y^2}{2} + y \right) dy + \left(2y - \frac{2y^2}{2} \right) \Big|_1^e \right] \\
&= \left[(\log e) \left(\frac{e^2}{2} + e \right) - \log 1 \cdot \left(\frac{1}{2} + 1 \right) - \int_1^e \left(\frac{y}{2} + 1 \right) dy + (2e - e^2) - (2 - 1) \right] \\
&= \left[\frac{e^2}{2} + e - \left(\frac{y^2}{4} + y \right) \Big|_1^e + 2e - e^2 - 1 \right] \\
&= \left[\frac{e^2}{2} + e - \frac{e^2}{4} - e + \frac{1}{4} + 1 + 2e - e^2 - 1 \right] \\
&= \left[\frac{1}{4} (1 + 8e - 3e^2) \right].
\end{aligned}$$

Example 39: Evaluate $\int_{-1}^1 \int_0^z \int_{x-z}^{x+z} (x+y+z) dx dy dz$ [JNTU, 2000; Cochin, 2005]

Solution: Integrating first with respect to y , keeping x and z constant,

$$\begin{aligned}
I &= \int_{-1}^1 \int_0^z \left[xy + \frac{y^2}{2} + yz \right]_{x-z}^{x+z} dx dz \\
&= \int_{-1}^1 \left(\int_0^z (4zx + 2z^2) dx \right) dz \\
&= \int_{-1}^1 \left[4z \frac{x^2}{2} + 2 \cdot z^2 \cdot x \right]_0^z dz \\
&= \int_{-1}^1 \left[4z \cdot \frac{z^2}{2} + 2z^2 \cdot z \right] dz \\
&= 4 \int_{-1}^1 z^3 dz = 4 \left[\frac{z^4}{4} \right]_{-1}^1 = 0
\end{aligned}$$

ASSIGNMENT 6

Evaluate the following integrals:

$$(1) \int_0^1 \int_0^2 \int_1^2 x^2 y z dx dy dz \quad (2) \int_{-a}^a \int_{-b}^b \int_{-c}^c (x^2 + y^2 + z^2) dx dy dz \quad \text{[VTU, 2000]}$$

$$(3) \int_0^4 \int_0^{2\sqrt{z}} \int_0^{\sqrt{4z-x^2}} dy dx dz \quad (4) \int_0^{\log 2} \int_0^x \int_0^{x+\log y} e^{x+y+z} dz dy dx \quad \text{[NIT Kurukshetra, 2008]}$$

5.10 VOLUME AS A DOUBLE INTEGRAL**(Geometrical Interpretation of the Double Integral)**

One of the most obvious use of double integral is the determination of volume of solids viz. 'volume between two surfaces'.

If $f(x, y)$ is a continuous and single valued function defined over the region R in the xy -plane with $z = f(x, y)$ as the equation of the surface. Let Γ be the closed curve which encloses R . Clearly, the surface R (viz. $z = f(x, y)$) is the orthogonal projection of S (viz. $z = f(x, y)$) in the xy -plane.

Divided R into elementary rectangles of area $\delta x \delta y$ by drawing lines parallel to the axis of x and y . On each of these rectangles erect prisms having their lengths parallel to the z -axis. The volume of each such prism is $z \delta x \delta y$.

(Division of R is performed with the lines $x = x_i$ ($i = 1, 2, \dots, m$) and $y = y_j$ ($j = 1, 2, \dots, n$). Through each line $x = x_i$, pass a plane parallel to yz -plane, and through each line $y = y_j$, pass a plane parallel to xz -plane. The rectangle ΔR_{ij} whose area is $\Delta A_{ij} = \Delta x_i \Delta y_j$ will be the base of a rectangle prism of height $f(x_{ij}, y_{ij})$, whose volume is approximately equal to the volume between the surface and the xy -plane $x = x_i - 1$,

$x = x_i$; $y = y_i - 1$ $y = y_i$. Then $\sum_{i=1}^m \sum_{j=1}^n f(\xi_{ij}, \eta_{ij}) \Delta x_i \Delta y_j$ gives an approximate value for volume V of

the prism of the cylinder enclosed between $z = f(x, y)$ and the xy -plane.

The volume V is the limit of the sum of each elementary volume $z \delta x \delta y$.

$$\therefore V = \lim_{\substack{\delta x \rightarrow 0 \\ \delta y \rightarrow 0}} \sum \sum z \delta x \delta y = \iint_R z dx dy = \iint_R f(x, y) dA$$

Note: In cylindrical co-ordinates, the equation of the surface becomes $z = f(r, \theta)$, elementary area $dA = r dr d\theta$ and volume $= \iint_R f(r, \theta) r dr d\theta$

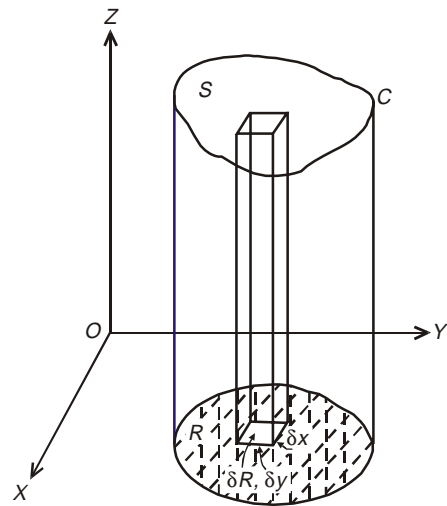

Fig. 5.49

Problems on Volume of a Solid with the Help of Double Integral

Example 40: Find the volume of the tetrahedron bounded by the plane $\frac{x}{a} + \frac{y}{b} + \frac{z}{c} = 1$ and the co-ordinate planes. [Burdwan, 2003]

Solution: Given, $\frac{x}{a} + \frac{y}{b} + \frac{z}{c} = 1 \Rightarrow z = f(x, y) = c\left(1 - \frac{x}{a} - \frac{y}{b}\right)$... (1)

If $f(x, y)$ is a continuous and single valued function over the region R (see Fig. 5.50) in the xy plane, then $z = f(x, y)$ is the equation of the surface. Let C be the closed curve that is the boundary of R . Using R as a base, construct a cylinder having elements parallel to the z -axis. This cylinder intersects $z = f(x, y)$ in a curve Γ , whose projection on the xy -plane is C .

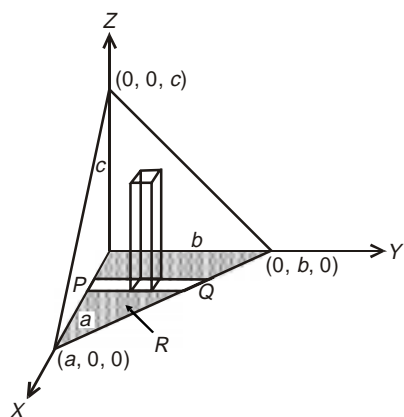

Fig. 5.50

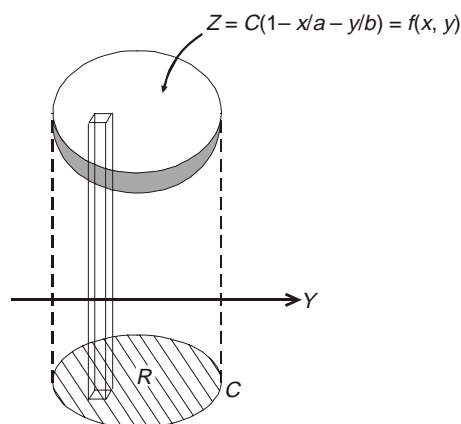

Fig. 5.51

The equation of the surface under which the region whose volume is required, may be written in the form (1) i.e., $z = c\left(1 - \frac{x}{a} - \frac{y}{b}\right)$.

Hence the volume of the region $= \iint_R z \, dA = \iint_R c\left(1 - \frac{x}{a} - \frac{y}{b}\right) \, dx \, dy$

The equation of the inter-section of the given surface with xy -plane is

$$\frac{x}{a} + \frac{y}{b} = 1 \quad \dots (2)$$

If the prisms are summed first in the y -direction they will be summed from $y = 0$ to the line $y = b\left(1 - \frac{x}{a}\right)$

Therefore,

$$V = \int_0^a \int_0^{b(1-x/a)} c\left(1 - \frac{x}{a} - \frac{y}{b}\right) \, dy \, dx$$

$$= c \int_0^a \left(y - \frac{xy}{a} - \frac{y^2}{2b} \right) \Big|_0^{b(1-x/a)} \, dx$$

$$\begin{aligned}
 &= c \int_0^a b \left(\frac{1}{2} - \frac{x}{a} + \frac{x^2}{2a^2} \right) dx \\
 &= cb \left[\frac{x}{2} - \frac{x^2}{2a} + \frac{x^3}{6a^2} \right]_0^a \\
 &= bc \left[\frac{a}{2} - \frac{a^2}{2a} + \frac{a^3}{6a^2} \right] = \frac{abc}{6}.
 \end{aligned}$$

Example 41: Prove that the volume enclosed between the cylinders $x^2 + y^2 = 2ax$ and $z^2 = 2ax$ is $\frac{128a^2}{15}$.

Solution: Let V be required volume which is enclosed by the cylinder $x^2 + y^2 = 2ax$ and the paraboloid $z^2 = 2ax$.

Only half of the volume is shown in Fig 5.52.

Now, it is evident from that $z = \sqrt{2ax}$ is to be evaluated over the circle $x^2 + y^2 = 2ax$ (with centre at $(a, 0)$ and radius a).

Here y varies from $-\sqrt{2ax-x^2}$ to $\sqrt{2ax-x^2}$ on the circle $x^2 + y^2 = 2ax$ and finally x varies from $x = 0$ to $x = 2a$

$$\begin{aligned}
 \therefore V &= 2 \int_0^{2a} \int_{-\sqrt{2ax-x^2}}^{\sqrt{2ax-x^2}} [z] dx dy \text{ as } z = f(x, y) \\
 &= 2 \int_0^{2a} \left(2 \cdot \int_0^{\sqrt{2ax-x^2}} \sqrt{2ax} \right) dy dx \\
 &= 4 \int_0^{2a} \sqrt{2ax} \left(\int_0^{\sqrt{2ax-x^2}} dy \right) dx \\
 &= 4 \int_0^{2a} \sqrt{2ax} |y|_0^{\sqrt{2ax-x^2}} dx = 4 \int_0^{2a} \sqrt{2ax} \sqrt{2ax-x^2} dx \\
 &= 4\sqrt{2a} \int_0^{2a} x\sqrt{2a-x} dx
 \end{aligned}$$

Let $x = 2a \sin^2 \theta$, so that $dx = 4a \sin \theta \cos \theta d\theta$. Further, for $x = 0$, $\theta = 0$ }
 $x = 2a$, $\theta = \frac{\pi}{2}$. }

$$\begin{aligned}
 \therefore V &= 4\sqrt{2a} \int_0^{\pi/2} 2a \sin^2 \theta \sqrt{2a} \cos \theta \cdot 4a \sin \theta \cos \theta d\theta \\
 &= 64 a^3 \int_0^{\pi/2} \sin^3 \theta \cos^2 \theta d\theta
 \end{aligned}$$

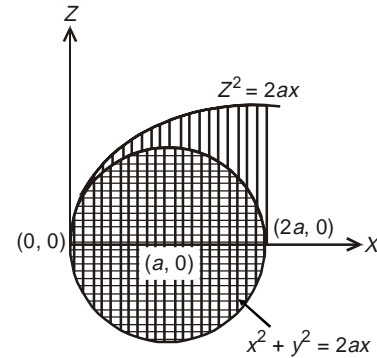

Fig. 5.52

$$\begin{aligned}
 &= 64 a^3 \frac{(p-1)(p-3)\dots(q-1)(q-3)\dots}{(p+q)(p+q-2)\dots} \cdot 1, \quad p=3, \quad q=2 \\
 &= 64 a^3 \frac{(3-1)1}{5 \cdot 3} = \frac{128 a^3}{15}.
 \end{aligned}$$

Problems based on Volume as a Double Integral in Cylindrical Coordinates

Example 42: Find the volume bounded by the cylinder $x^2 + y^2 = 4$ and the hyperboloid $x^2 + y^2 - z^2 = 1$.

Solution: In cartesian co-ordinates, the section of the given hyperboloid $x^2 + y^2 - z^2 = 1$ in the xy plane ($z = 0$) is the circle $x^2 + y^2 = 1$, where as at the top and at the bottom end (along the z -axis i.e., $z = \pm\sqrt{3}$) it shares common boundary with the circle $x^2 + y^2 = 4$ (Fig. 5.53 and 5.54).

Here we need to calculate the volume bounded by the two bodies (i.e., the volume of shaded portion of the geometry).

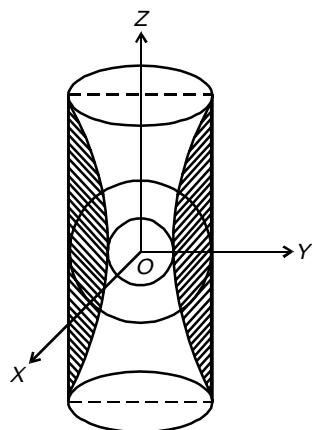

Fig. 5.53

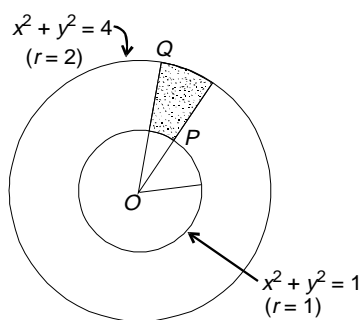

Fig. 5.54

(Best example of this geometry is a *solid damroo* in a *concentric long hollow drum*.)

In cylindrical polar coordinates, we see that here r varies from $r = 1$ to $r = 2$ and θ varies from 0 to 2π .

$$\begin{aligned}
 \therefore V &= 2 \left[\iint z \, dx \, dy \right] = 2 \left[\iint f(r, \theta) r \, dr \, d\theta \right] \\
 &= 2 \left[\int_0^{2\pi} \int_1^2 \sqrt{r^2 - 1} \, r \, dr \, d\theta \right] \quad (\because x^2 + y^2 - z^2 = 1 \Rightarrow z = \sqrt{x^2 + y^2 - 1}) \\
 &= 2 \int_0^{2\pi} \left(\int_1^2 \frac{1}{3} d(r^2 - 1)^{\frac{3}{2}} \right) d\theta
 \end{aligned}$$

$$\begin{aligned}
 &= 2 \int_0^{2\pi} \frac{(r^2 - 1)^{\frac{3}{2}}}{3} \Big|_1^2 d\theta \\
 &= 2\sqrt{3} \int_0^{2\pi} d\theta = 4\pi\sqrt{3}.
 \end{aligned}$$

Example 43: Find the volume bounded by the cylinder $x^2 + y^2 = 4$ and the planes $y + z = 4$ and $z = 0$. [KUK, 2000; MDU, 2002; Cochin, 2005; SVTU, 2007]

Solution: From Fig. 5.55, it is very clear that $z = 4 - y$ is to be integrated over the circle $x^2 + y^2 = 4$ in the xy -plane.

To cover the shaded portion, x varies from $-\sqrt{4 - y^2}$ to $\sqrt{4 - y^2}$ and y varies from -2 to 2 . Hence the desired volume,

$$\begin{aligned}
 V &= \int_{-2}^2 \int_{-\sqrt{4-y^2}}^{\sqrt{4-y^2}} z \, dx \, dy \\
 &= 2 \int_{-2}^2 \int_0^{\sqrt{4-y^2}} (4 - y) \, dx \, dy \\
 &= 2 \int_{-2}^2 (4 - y) \left(\int_0^{\sqrt{4-y^2}} dx \right) dy \\
 &= 2 \int_{-2}^2 (4 - y) \sqrt{4 - y^2} \, dy \\
 &= 2 \int_{-2}^2 [4\sqrt{4 - y^2} - y\sqrt{4 - y^2}] \, dy \\
 &= 8 \int_{-2}^2 \sqrt{4 - y^2} \, dy - 0
 \end{aligned}$$

(The second term vanishes as the integrand is an odd function)

$$= 8 \left[\frac{y\sqrt{4 - y^2}}{2} + \frac{4}{2} \sin^{-1} \frac{y}{2} \right]_{-2}^2 = 16\pi.$$

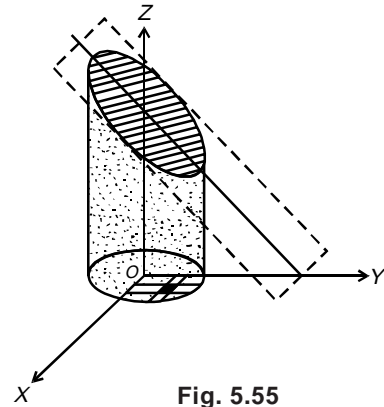

Fig. 5.55

ASSIGNMENT 7

- Find the volume enclosed by the coordinate planes and the portion of the plane $lx + my + nz = 1$ lying in the first quadrant.
- Obtain the volume bounded by the surface $z = c \left(1 - \frac{x}{a} \right) \left(1 - \frac{y}{b} \right)$ and the quadrant of the elliptic cylinder $\frac{x^2}{a^2} + \frac{y^2}{b^2} = 1$

[Hint: Use elliptic polar coordinates $x = a \cos \theta$, $y = b \sin \theta$]

5.11 VOLUME AS A TRIPLE INTEGRAL

Divide the given solid by planes parallel to the coordinate plane into rectangular parallelepiped of elementary volume $\delta x \delta y \delta z$.

Then the total volume V is the limit of the sum of all elementary volume i.e.,

$$V = \lim_{\substack{\delta x \rightarrow 0 \\ \delta y \rightarrow 0 \\ \delta z \rightarrow 0}} \sum \sum \sum \delta x \delta y \delta z = \iiint dx dy dz$$

Problems based on Volume as a Triple Integral in cartesian Coordinate System

Example 44: Find the volume common to the cylinders $x^2 + y^2 = a^2$ and $x^2 + z^2 = a^2$.

Solution: The sections of the cylinders $x^2 + y^2 = a^2$ and $x^2 + z^2 = a^2$ are the circles $x^2 + y^2 = a^2$ and $x^2 + z^2 = a^2$ in xy and xz plane respectively.

Here in the picture, one-eighth part of the required volume (covered in the 1st octant) is shown.

Clearly, in the common region, z varies from 0 to $\sqrt{a^2 - x^2}$ i.e., $\sqrt{a^2 - 1x^2 - 0y^2}$, and x and y vary on the circle $x^2 + y^2 = a^2$.

The required volume

$$\begin{aligned} \therefore V &= 8 \int_0^a \int_{y_1=0}^{y_2=\sqrt{a^2-x^2}} \int_{z_1=0}^{z_2=\sqrt{a^2-x^2-0y^2}} dz dy dx \\ &= 8 \int_0^a \int_0^{\sqrt{a^2-x^2}} \left(z \Big|_0^{\sqrt{a^2-x^2}} \right) dy dx \\ &= 8 \int_0^a \left(\int_0^{\sqrt{a^2-x^2}} \sqrt{a^2-x^2} dy \right) dx \\ &= 8 \int_0^a \left(\sqrt{a^2-x^2} \right) \left(\int_0^{\sqrt{a^2-x^2}} dy \right) dx \\ &= 8 \int_0^a \sqrt{a^2-x^2} \left(\sqrt{a^2-x^2} - 0 \right) dx \\ &= 8 \int_0^a (a^2 - x^2) dx = 8 \left[\left(a^2 x - \frac{x^3}{3} \right) \Big|_0^a \right] \\ &= 8 \left(a^3 - \frac{a^3}{3} \right) = \frac{16a^3}{3}. \end{aligned}$$

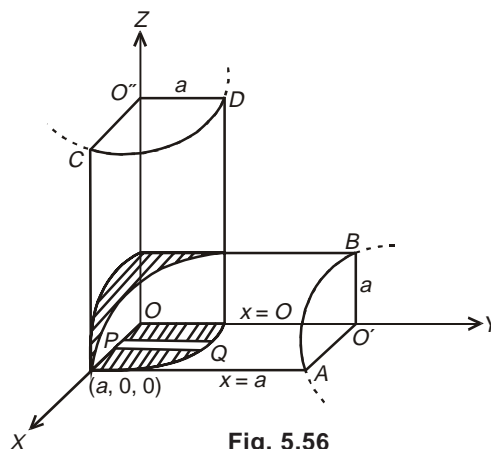

Fig. 5.56

Example 45: Find the volume bounded by the xy plane, the cylinder $x^2 + y^2 = 1$ and the plane $x + y + z = 3$.

Solution: Let $V(x, y, z)$ be the desired volume enclosed laterally by the cylinder $x^2 + y^2 = 1$ (in the xy -plane) and on the top, by the plane $x + y + z = 3$ (= a say).

Clearly, the limits of z are from 0 (on the xy -plane) to $z = (3 - x - y)$ and x and y vary on the circle $x^2 + y^2 = 1$

$$\begin{aligned} \therefore V(x, y, z) &= \int_{-1}^1 \int_{-\sqrt{1-x^2}}^{\sqrt{1-x^2}} \int_0^{3-x-y} dz dy dx \\ &= \int_{-1}^1 \int_{-\sqrt{1-x^2}}^{\sqrt{1-x^2}} \left(z \Big|_0^{3-x-y} \right) dy dx \\ &= \int_{-1}^1 \left(\int_{-\sqrt{1-x^2}}^{\sqrt{1-x^2}} (3-x-y) dy \right) dx \\ &= \int_{-1}^1 \left[3y - xy - \frac{y^2}{2} \right]_{-\sqrt{1-x^2}}^{\sqrt{1-x^2}} dx \end{aligned}$$

$$\Rightarrow I = \int_{-1}^1 (6 \times \sqrt{1-x^2} - 2x\sqrt{1-x^2}) dx$$

$$\left. \begin{array}{l} \text{On taking } x = \sin \theta, \text{ we get } dx = d\theta; \text{ For } x = -1, \theta = -\frac{\pi}{2} \\ \text{For } x = 1, \theta = \frac{\pi}{2} \end{array} \right\}$$

Thus,

$$\begin{aligned} V &= \int_{-\pi/2}^{\pi/2} (6\sqrt{1-\sin^2 \theta} - 2\sin \theta \sqrt{1-\sin^2 \theta}) \cos \theta d\theta \\ &= \int_{-\pi/2}^{\pi/2} (6\cos^2 \theta - 2\sin \theta \cos^2 \theta) d\theta \\ &= 6 \times 2 \int_0^{\pi/2} \cos^2 \theta d\theta - 2 \int_{-\pi/2}^{\pi/2} \sin \theta \cos^2 \theta d\theta \\ &\quad \text{Ist} \qquad \qquad \text{IInd} \\ &= 12 \frac{(2-1)}{2} \cdot \frac{\pi}{2} + 2 \frac{\cos^3 \theta}{3} \Big|_{-\pi/2}^{\pi/2} = 3\pi + \frac{2}{3} \times 0 = 3\pi \end{aligned}$$

Using $\int_0^{\pi/2} \cos^p \theta d\theta = \frac{(p-1)(p-3)\dots}{p(p-2)\dots} \times \left(\frac{\pi}{2}, \text{ only if } p \text{ is even} \right)$ and

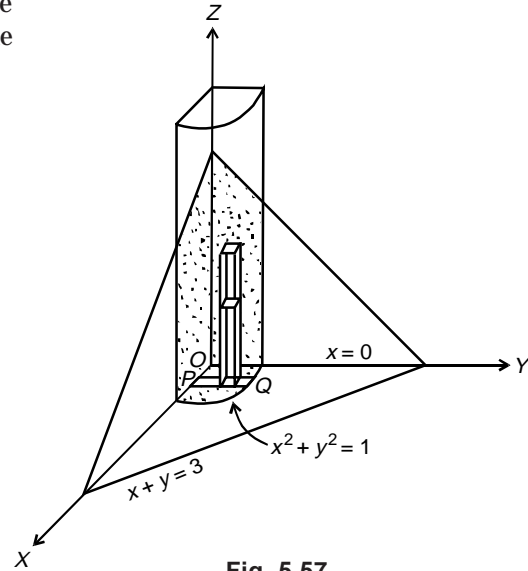

Fig. 5.57

$$\int f'(x) f^n(x) dx = \frac{f^{n+1}(x)}{n+1} \text{ for Ist and IInd integral respectively}$$

Example 46: Find the volume bounded by the ellipsoid $\frac{x^2}{a^2} + \frac{y^2}{b^2} + \frac{z^2}{c^2} = 1$.

[MDU, 2000; KUK, 2001; Kottayam, 2005; PTU, 2006]

Solution: Considering the symmetry, the desired volume is 8 times the volume of the ellipsoid into the positive octant.

The ellipsoid cuts the XOY plane in the ellipse

$$\frac{x^2}{a^2} + \frac{y^2}{b^2} = 1 \text{ and } z = 0.$$

Therefore, the required volume lies between the ellipsoid

$$z = c\sqrt{1 - \frac{x^2}{a^2} - \frac{y^2}{b^2}}$$

and the plane XOY (i.e., $z = 0$) and is bounded on the sides by the planes $x = 0$ and $y = 0$

Hence,

$$\begin{aligned} V &= 8 \int_0^a \int_0^b \int_0^{c\sqrt{1 - \frac{x^2}{a^2} - \frac{y^2}{b^2}}} dz dy dx \\ &= 8 \int_0^a \int_0^b \sqrt{1 - \frac{x^2}{a^2}} c \sqrt{1 - \frac{x^2}{a^2} - \frac{y^2}{b^2}} dy dx \\ &= 8 \int_0^a \left(\int_0^\alpha \frac{c}{b} \sqrt{\alpha^2 - y^2} dy \right) dx \quad \left(\text{taking } \sqrt{\left(1 - \frac{x^2}{a^2}\right)} = \frac{\alpha}{b} \right) \end{aligned}$$

$$V = 8 \frac{c}{b} \int_0^a \left[\frac{y\sqrt{\alpha^2 - y^2}}{2} + \frac{\alpha^2}{2} \sin^{-1} \frac{y}{\alpha} \right]_0^\alpha dx$$

$$\left(\text{Using formula } \int \sqrt{a^2 - x^2} dx = \frac{x}{2} \sqrt{a^2 - x^2} + \frac{a^2}{2} \tan^{-1} \frac{x}{a} \right)$$

$$= 8 \frac{c}{b} \int_0^a \left[0 + \frac{\alpha^2}{2} \sin^{-1} 1 \right] dx$$

$$= \frac{4c}{b} \int_0^a \frac{\pi}{2} \alpha^2 dx = \frac{2\pi c}{b} \int_0^a b^2 \left(1 - \frac{x^2}{a^2}\right) dx, \quad \alpha = b\sqrt{1 - \frac{x^2}{a^2}}$$

$$= 2\pi bc \left[x - \frac{1}{a^2} \frac{x^3}{3} \right]_0^a$$

$$= \frac{4}{3} \pi abc.$$

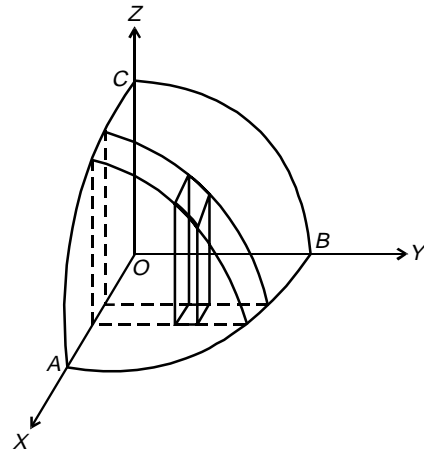

Fig. 5.58

Example 47: Evaluate the integral $\iiint \frac{dx dy dz}{\sqrt{a^2 - x^2 - y^2 - z^2}}$ taken throughout the volume of the sphere. [MDU, 2000]

Solution: Here for the given sphere $x^2 + y^2 + z^2 = a^2$, any of the three variables x, y, z can be expressed in term of the other two, say $z = \pm \sqrt{a^2 - x^2 - y^2}$.

In the xy -plane, the projection of the sphere is the circle $x^2 + y^2 = a^2$.

Thus,

$$\begin{aligned}
 I &= 8 \int_0^a \int_0^{\sqrt{a^2-x^2}} \int_0^{\sqrt{a^2-x^2-y^2}} \frac{dx dy dz}{\sqrt{a^2 - x^2 - y^2 - z^2}} \\
 &= 8 \int_0^a \left(\int_0^{\sqrt{a^2-x^2}} \left(\int_0^{\sqrt{a^2-x^2-y^2}} \frac{dz}{\sqrt{\alpha^2 - z^2}} \right) dy \right) dx, \alpha^2 = (a^2 - x^2 - y^2) \\
 &= 8 \int_0^a \left(\int_0^{\sqrt{a^2-x^2}} \left(\sin^{-1} \frac{z}{\alpha} \right)_0^\alpha dy \right) dx \\
 &= 8 \int_0^a \left(\int_0^{\sqrt{a^2-x^2}} (\sin^{-1} 1 - \sin^{-1} 0) dy \right) dx \\
 &= 8 \frac{\pi}{2} \int_0^a \left(\int_0^{\sqrt{a^2-x^2}} dy \right) dx = 4\pi \int_0^a \left(y \Big|_0^{\sqrt{a^2-x^2}} \right) dx \\
 &= 4\pi \int_0^a \sqrt{a^2 - x^2} dx = 4\pi \left[\frac{x\sqrt{a^2 - x^2}}{2} + \frac{a^2}{2} \sin^{-1} \frac{x}{a} \right]_0^a \\
 &= 4\pi \left[0 + \frac{a^2}{2} \frac{\pi}{2} \right] I = \pi^2 a^2.
 \end{aligned}$$

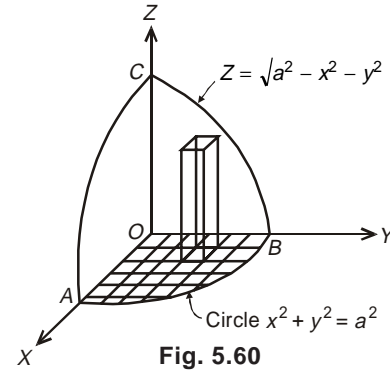

Example 48: Evaluate $\int (x + y + z) dx dy dz$ over the tetrahedron bounded by the planes $x = 0, y = 0, z = 0$ and $x + y + z = 1$.

Solution: The integration is over the region R (shaded portion) bounded by the plane $x = 0, y = 0, z = 0$ and the plane $x + y + z = 1$.

The area OAB , in xy plane is bounded by the lines $x + y = 1, x = 0, y = 0$

Hence for any pt. (x, y) within this triangle, z goes from xy plane to plane ABC (viz. the surface of the tetrahedron) or in other words, z changes from $z = 0$ to $z = 1 - x - y$. Likewise in plane xy, y as a function x varies from $y = 0$ to $y = 1 - x$ and finally x varies from 0 to 1 .

whence,

$$\begin{aligned}
 I &= \int \int \int_{(over R)} (x + y + z) dx dy dz \\
 &= \int_0^1 \left(\int_0^{1-x} \left(\int_0^{1-x-y} (x + y + z) dz \right) dy \right) dx
 \end{aligned}$$

$$\begin{aligned}
 &= \int_0^a \int_0^{1-x} \left((x+y)z + \frac{z^2}{2} \right) \Big|_0^{1-x-y} dy dx \\
 &= \int_0^a \int_0^{1-x} \left[(x+y)(1-x-y) + \frac{(1-x-y)^2}{2} \right] dy dx \\
 &= \int_0^1 \int_0^{1-x} \frac{1}{2} (1-x-y)(1+x+y) dy dx \\
 &= \int_0^1 \int_0^{1-x} \frac{1}{2} [1 - (x+y)^2] dy dx \\
 &= \frac{1}{2} \int_0^1 \left[y - \frac{(x+y)^3}{3} \right]_0^{1-x} dx, \\
 &= \frac{1}{2} \int_0^1 \left[(1-x) - \left(\frac{1}{3} - \frac{x^3}{3} \right) \right] dx \\
 &= \frac{1}{2} \left[\frac{2}{3}x - \frac{x^2}{2} + \frac{x^4}{12} \right]_0^1 \\
 &= \frac{1}{2} \left[\frac{2}{3} - \frac{1}{2} + \frac{1}{12} \right] = \frac{1}{8}
 \end{aligned}$$

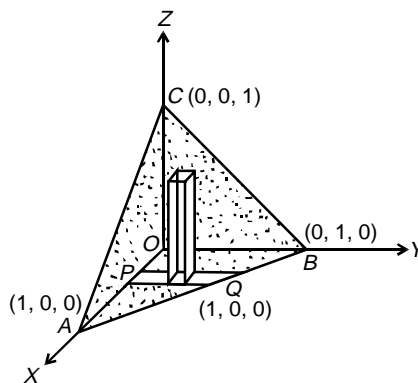

Fig. 5.61

ASSIGNMENT 8

1. Find the volume of the tetrahedron bounded by co-ordinate planes and the plane $\frac{x}{a} + \frac{y}{b} + \frac{z}{c} = 1$, by using triple integration [KUK, 2002]
2. Find the volume bounded by the paraboloid $x^2 + y^2 = az$, the cylinder $x^2 + y^2 = 2ay$ and the plane $z = 0$.

5.12. VOLUMES OF SOLIDS OF REVOLUTION AS A DOUBLE INTEGRAL

Let $P(x, y)$ be any point in a region R enclosing an elementary area $dx dy$ around it. This elementary area on revolution about x -axis form a ring of volume,

$$\delta V = \pi[(y + \delta y)^2 - y^2] \delta x = 2\pi y \delta x \delta y \quad \dots(1)$$

Hence the total volume of the solid formed by revolution of this region R about x -axis is,

$$V = \iint_R 2\pi y dx dy \quad \dots(2)$$

Similarly, if the same region is revolved about y -axis, then the required volume becomes

$$V = \iint_R 2\pi x dx dy \quad \dots(3)$$

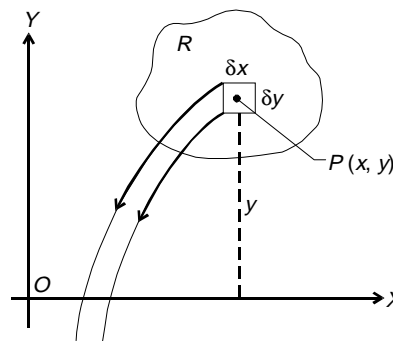

Fig. 5.62

Expressions for above volume in polar coordinates **about the initial line** and **about the pole** are $\iint_R 2\pi r^2 \sin \theta \, dr \, d\theta$ and $\iint_R 2\pi r^2 \cos \theta \, dr \, d\theta$ respectively.

Example 49: Find by double integration, the volume of the solid generated by revolving the ellipse $\frac{x^2}{a^2} + \frac{y^2}{b^2} = 1$ about y-axis.

Solution: As the ellipse $\frac{x^2}{a^2} + \frac{y^2}{b^2} = 1$ is symmetrical about the y-axis, the volume generated by the left and the right halves overlap.

Hence we shall consider the revolution of the right-half ABD for which x -varies from 0 to $a\sqrt{1 - \frac{y^2}{b^2}}$ and y -varies from $-b$ to b .

$$\begin{aligned} \therefore V &= \int_{-b}^b \int_0^{a\sqrt{1 - \frac{y^2}{b^2}}} 2\pi x \, dx \, dy \\ &= 2\pi \int_{-b}^b \left[\frac{x^2}{2} \right]_0^{a\sqrt{1 - \frac{y^2}{b^2}}} dy = \frac{\pi a^2}{b^2} \int_{-b}^b (b^2 - y^2) dy \\ &= 2\pi \frac{a^2}{b^2} \int_0^b (b^2 - y^2) dy = \frac{2\pi a^2}{b^2} \left[b^2 y - \frac{y^3}{3} \right]_0^b \\ &= \frac{4}{3} \pi a^2 b. \end{aligned}$$

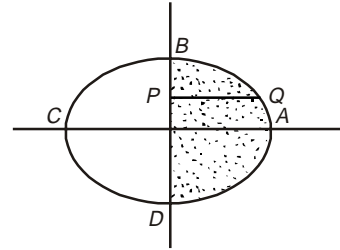

Fig. 5.63

Example 50: The area bounded by the parabola $y^2 = 4x$ and the straight lines $x = 1$ and $y = 0$, in the first quadrant is revolved about the line $y = 2$. Find by double integration the volume of the solid generated.

Solution: Draw the standard parabola $y^2 = 4x$ to which the straight line $y = 2$ meets in the point $P(1, 2)$, Fig. 5.64.

Now the dotted portion *i.e.*, the area enclosed by parabola, the line $x = 1$ and $y = 0$ is revolved about the line $y = 2$.

\therefore The required volume,

$$\begin{aligned} V &= \int_0^1 \int_0^{2\sqrt{x}} 2\pi(2 - y) \, dx \, dy \\ &= 2\pi \int_0^1 \left[2y - \frac{y^2}{2} \right]_0^{2\sqrt{x}} dx = 2\pi \int_0^1 (4\sqrt{x} - 2x) dx \\ &= 2\pi \left[\frac{8}{3} x^{3/2} - x^2 \right]_0^1 = \frac{10\pi}{3} \end{aligned}$$

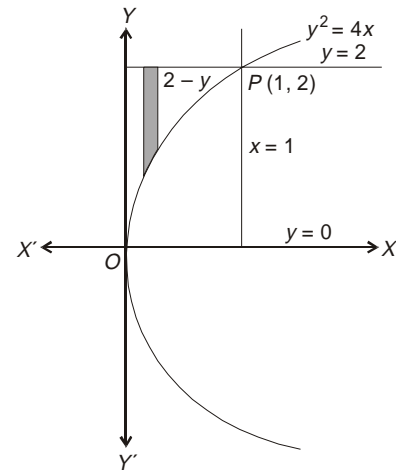

Fig. 5.64

Example 51: Calculate by double integration, the volume generated by the revolution of the cardioid $r = a(1 - \cos\theta)$ about its axis. [KUK, 2007, 2009]

Soluton: On considering the upper half of the cardioid, because due to symmetry the lower half generates the same volume.

$$\begin{aligned} \therefore V &= \int_0^\pi \int_0^{a(1-\cos\theta)} 2\pi r^2 \sin\theta \, dr \, d\theta \\ &= 2\pi \int_0^\pi \left[\frac{r^3}{3} \right]_0^{a(1-\cos\theta)} \sin\theta \, d\theta \\ &= \frac{2\pi a^3}{3} \int_0^\pi (1 - \cos\theta)^3 \sin\theta \, d\theta \\ &= \frac{2\pi a^3}{3} \left[\frac{(1 - \cos\theta)^4}{4} \right]_0^\pi = \frac{8\pi a^3}{3}. \end{aligned}$$

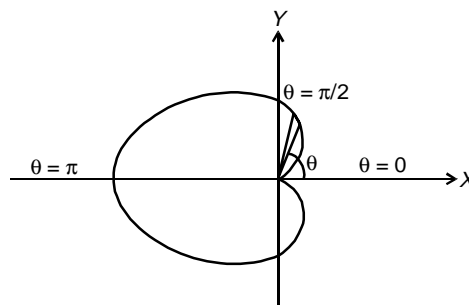

Fig. 5.65

Example 52: By using double integral, show that volume generated by revolution of cardioid $r = a(1 + \cos\theta)$ about the initial line is $\frac{8}{3}\pi a^3$.

Solution: The required volume

$$\begin{aligned} &= \int_0^\pi \int_0^{a(1+\cos\theta)} 2\pi r^2 \sin\theta \, dr \, d\theta \\ &= 2\pi \int_0^\pi \left[\frac{r^3}{3} \right]_0^{a(1+\cos\theta)} \sin\theta \, d\theta \\ &= 2\pi \int_0^\pi a^3 (1 + \cos\theta)^3 \sin\theta \, d\theta \\ &= \frac{2\pi a^3}{3} \left[-\frac{(1 + \cos\theta)^4}{4} \right]_0^\pi \\ &= -\frac{2\pi a^3}{3} \left[0 - \frac{2^4}{4} \right] = \frac{8\pi a^3}{3}. \end{aligned}$$

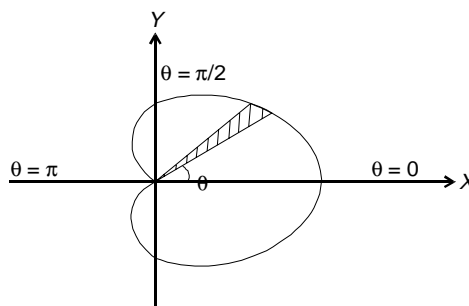

Fig. 5.66

ASSIGNMENT 9

1. Find by double integration the volume of the solid generated by revolving the ellipse $\frac{x^2}{a^2} + \frac{y^2}{b^2} = 1$ about the X-axis.
2. Find the volume generated by revolving a quadrant of the circle $x^2 + y^2 = a^2$, about its diameter.
3. Find the volume generated by the revolution of the curve $y^2(2a - x) = x^3$, about its asymptote through four right angles.
4. Find the volume of the solid obtained by the revolution of the lemniscate $r^2 = a^2 \cos 2\theta$ about the initial line. [Jammu Univ., 2002]

5.13. CHANGE OF VARIABLE IN TRIPLE INTEGRAL

For transforming elementary area or the volume from one sets of coordinate to another, the necessary role of ‘Jacobian’ or ‘functional determinant’ comes into picture.

(a) Triple Integral Under General Transformation

Here
$$\iiint_{R(x,y,z)} f(x,y,z) dx dy dz = \iiint_{R'(u,v,w)} f(u,v,w) |J| du dv dw; \text{ where } J = \frac{\partial(x,y,z)}{\partial(u,v,w)} (\neq 0) \dots(1)$$

Since in the case of three variables $u(x, y, z), v(x, y, z), w(x, y, z)$ be continuous together with their first partial derivatives, the Jacobian of u, v, w with respect to x, y, z is defined by

$$\begin{vmatrix} \frac{\partial u}{\partial x} & \frac{\partial v}{\partial x} & \frac{\partial w}{\partial x} \\ \frac{\partial u}{\partial y} & \frac{\partial v}{\partial y} & \frac{\partial w}{\partial y} \\ \frac{\partial u}{\partial z} & \frac{\partial v}{\partial z} & \frac{\partial w}{\partial z} \end{vmatrix}$$

(b) Triple Integral in Cylindrical Coordinates

Here
$$\iiint_R f(x,y,z) dx dy dz = \iiint f(r,\theta,z) |J| dr d\theta dz, \text{ where } |J| = r$$

The position of a point P in space in cylindrical coordinates is determined by the three numbers r, θ, z where r and θ are polar co-ordinates of the projection of the point P on the xy -plane and z is the z coordinate of P i.e., distance of the point (P) from the xy -plane with the plus sign if the point (P) lies above the xy -plane, and minus sign if below the xy -plane (Fig. 5.67).

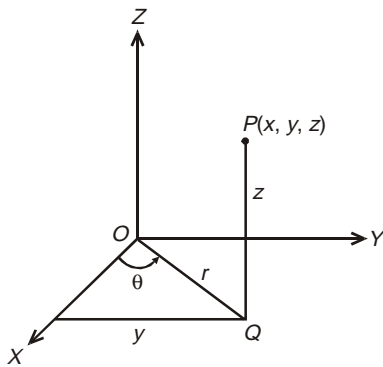

Fig. 5.67

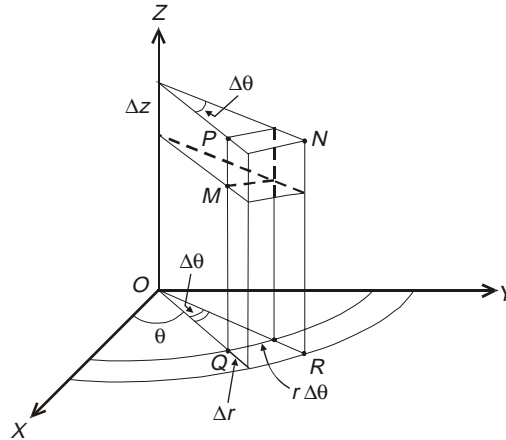

Fig. 5.68

In this case, divide the given three dimensional region $R'(r, \theta, z)$ into elementary volumes by coordinate surfaces $r = r_i, \theta = \theta_j, z = z_k$ (viz. half plane adjoining z -axis, circular cylinder axis coincides with Z -axis, planes perpendicular to z -axis). The

curvilinear 'prism' shown in Fig. 5. 68 is a volume element of which elementary base area is $r \Delta r \Delta \theta$ and height Δz , so that $\Delta v = r \Delta r \Delta \theta \Delta z$.

Here θ is the angle between OQ and the positive x -axis, r is the distance OQ and z is the distance QP . From the Fig. 5.62, it is evident that

$$x = r \cos \theta, y = r \sin \theta, z = z \text{ and so that,}$$

$$J \left(\begin{matrix} x, y, z \\ u, v, w \end{matrix} \right) = \begin{vmatrix} \cos \theta & \sin \theta & 0 \\ -r \sin \theta & r \cos \theta & 0 \\ 0 & 0 & 1 \end{vmatrix} = r \quad \dots(2)$$

Hence, the triple integral of the function $F(r, \theta, z)$ over R' becomes

$$V = \iiint_{R(r, \theta, z)} F(r, \theta, z) r dr d\theta dz \quad \dots(3)$$

(c) Triple Integral in Spherical Polar Coordinates

Here $V = \iiint_R f(x, y, z) dx dy dz = \iiint_R [f(r, \theta, \phi)] |J| dr d\theta d\phi$, where $|J| = r^2 \sin \theta$

The position of a point P in space in spherical coordinates is determined by the three variables r, θ, ϕ where r is the distance of the point (P) from the origin and so called radius vector, θ is the angle between the radius vector on the xy -plane and the x -axis to count from this axis in a positive sense viz. counter-clockwise.

For any point in space in spherical coordinates, we have

$$0 \leq r \leq \infty, 0 \leq \theta \leq \pi, 0 \leq \phi \leq 2\pi.$$

Divide the region 'R' into elementary volumes ΔV by coordinate surfaces, $r = \text{constant}$ (sphere), $\theta = \text{constant}$ (conic surfaces with vertices at the origin), $\phi = \text{constant}$ (half planes passing through the Z -axis).

To within infinitesimal of higher order, the volume element Δv may be considered a parallelepiped with edges of length $\Delta r, r \Delta \theta, r \sin \theta \Delta \phi$. Then the volume element becomes $\Delta V = r^2 \sin \theta \Delta r \Delta \theta \Delta \phi$.

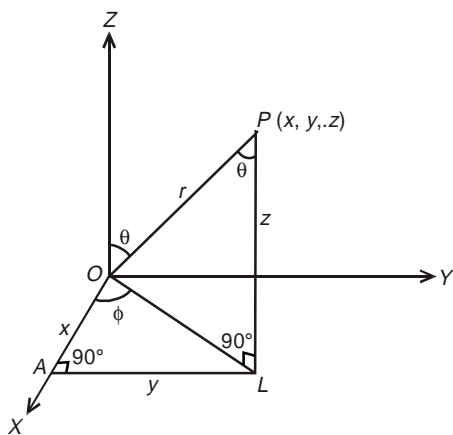

Fig. 5.69

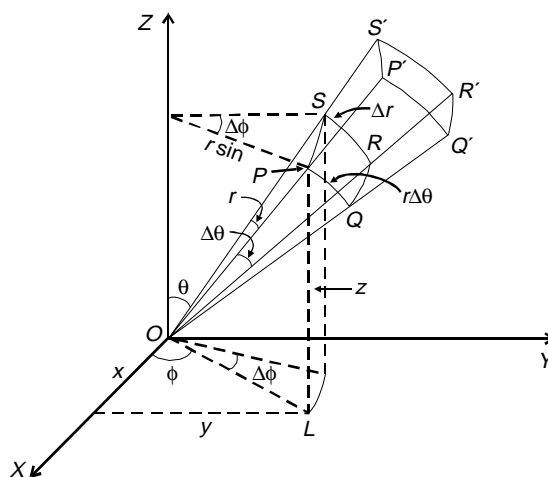

Fig. 5.70

For calculation purpose, it is evident from the Fig. 5.69 that in triangles, OAL and OPL ,

$$\begin{aligned}x &= OL \cos \phi = OP \cos(90 - \theta) \cdot \cos \phi = r \sin \theta \cos \phi, \\y &= OL \sin \phi = OP \sin \theta \cdot \sin \phi = r \sin \theta \sin \phi, \\z &= r \cos \theta.\end{aligned}$$

$$\text{Thus, } J = \frac{\partial(x, y, z)}{\partial(r, \theta, \phi)} = \begin{vmatrix} \sin \theta \cos \phi & \sin \theta \sin \phi & \cos \theta \\ r \cos \theta \cos \phi & r \cos \theta \sin \phi & -r \sin \theta \\ -r \sin \theta \sin \phi & r \sin \theta \cos \phi & 0 \end{vmatrix} = r^2 \sin \theta$$

Problems Volume as a Triple Integral in Cylindrical Co-ordinates

Example 53: Find the volume intercepted between the paraboloid $x^2 + y^2 = 2az$ and the cylinder $x^2 + y^2 - 2ax = 0$.

Solution: Let V be required volume of the cylinder $x^2 + y^2 - 2ax = 0$ intercepted by the paraboloid $x^2 + y^2 = 2az$.

Transforming the given system of equations to polar-cylindrical co-ordinates.

$$\text{Let } \left. \begin{array}{l} x = r \cos \theta \\ y = r \sin \theta \\ z = z \end{array} \right\} \text{ so that } V(x, y, z) = V(r, \theta, z)$$

By above substitution the equation of the paraboloid becomes

$$\begin{aligned}r^2 = 2az &\Rightarrow z = \frac{r^2}{2a} \text{ and the cylinder } x^2 + y^2 = 2ax \text{ gives} \\ r^2 - 2ar \cos \theta = 0 &\Rightarrow r(r - 2a \cos \theta) = 0 \text{ with } r = 0 \text{ and} \\ r = 2a \cos \theta.\end{aligned}$$

Thus, it is clear from the Fig. 5.71 that z varies from 0 to $\frac{r^2}{2a}$ and r as a function of θ varies from 0 to $2a \cos \theta$ with θ as limits 0 to 2π . Geometry clearly shows the volume covered under

the +ve octant only, i.e. $\frac{1}{4}$ th of the full volume.

$$\begin{aligned}V_{(x,y,z)} &= V'_{(r,\theta,z)} = 4 \int_0^{\pi/2} \int_{r=0}^{r=2a \cos \theta} \int_{z=0}^{z=r^2/2a} r dz dr d\theta, \text{ as } |J| = r \\ &= 4 \int_0^{\pi/2} \left(\int_0^{2a \cos \theta} r \left[z \right]_0^{r^2/2a} r dr \right) d\theta \\ &= 4 \int_0^{\pi/2} \left(\int_0^{2a \cos \theta} \frac{r^3}{2a} dr \right) d\theta \\ &= 4 \frac{1}{2a} \int_0^{\pi/2} \frac{r^4}{4} \Big|_0^{2a \cos \theta} d\theta\end{aligned}$$

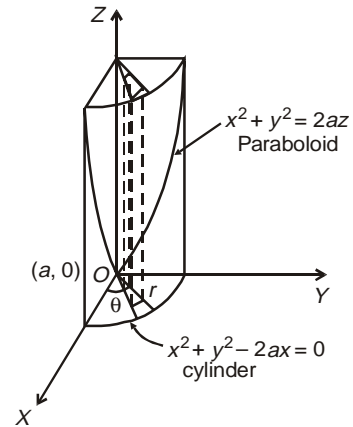

Fig. 5.71

$$\begin{aligned}
 &= 4 \frac{1}{2a} \int_0^{\pi/2} \frac{2^4 a^4}{4} \cos^4 \theta \, d\theta \\
 &= 2^3 a^3 \frac{(4-1)(4-3)}{4 \times 2} \frac{\pi}{2} \\
 &= \frac{3\pi a^3}{2}.
 \end{aligned}$$

Example 54: Find the volume of the region bounded by the paraboloid $az = x^2 + y^2$ and the cylinder $x^2 + y^2 = b^2$. Also find the integral in case when $a = 2$ and $b = 2$.

Solution: On using the cylindrical polar co-ordinates (r, θ, z) with $x = r\cos\theta, y = r\sin\theta$, so that the equations of the cylinder and that of the paraboloid are $r = b$ and $z = \frac{r^2}{a}$ respectively.

See Fig. 5.72, only one-fourth of the common volume is shown.

Hence in the common region, z varies from $z = 0$ to $z = \frac{r^2}{a}$ and r and θ varies on the circle from 0 to b and 0 to $\frac{\pi}{2}$ respectively.

\therefore The desired volume

$$\begin{aligned}
 V &= 4 \int_0^{\pi/2} \int_0^b \int_0^{r^2/a} r \, dr \, d\theta \, dz \\
 &= 4 \int_0^{\pi/2} \left(\int_0^b r \, dr \left(\int_0^{r^2/a} dz \right) \right) d\theta \\
 &= 4 \int_0^{\pi/2} \left(\int_0^b r \left(\frac{r^2}{a} \right) dr \right) d\theta \\
 &= \frac{4}{a} \int_0^{\pi/2} \left(\frac{r^4}{4} \Big|_0^b \right) d\theta \\
 &= \frac{4}{a} \times \frac{b^4}{4} \theta \Big|_0^{\pi/2} = \frac{\pi b^4}{2a}
 \end{aligned}$$

As a particular case, when $a = 2, b = 2$, then

$$V = \frac{\pi(2)^4}{2 \times 2} = 4\pi$$

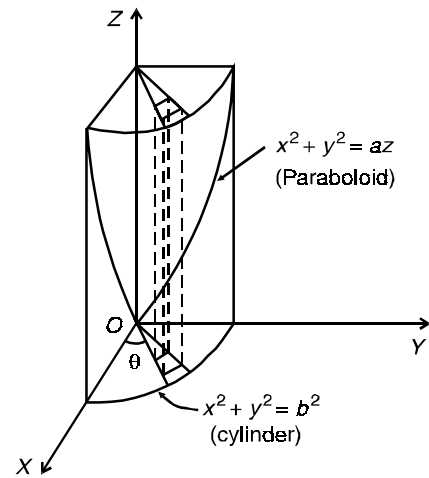

Fig. 5.72

Problems on Volume in Polar Spherical Co-ordinates

Example 55: Find the volume common to the sphere $x^2 + y^2 + z^2 = a^2$ and the cone $x^2 + y^2 = z^2$

OR

Find the volume cut by the cone $x^2 + y^2 = z^2$ from the sphere $x^2 + y^2 + z^2 = a^2$.

[NIT Kurukshetra, 2010]

Solution: For the given sphere, $x^2 + y^2 + z^2 = a^2$ and the cone $x^2 + y^2 = z^2$, the centre of the sphere is $(0, 0, 0)$ and the vertex of the cone is origin. Therefore, the volume common to the two bodies is symmetrical about the plane $z = 0$, i.e. the required volume, $V = 2 \iiint dx dy dz$

$$\left. \begin{array}{l} x = r \sin \theta \cos \phi \\ y = r \sin \theta \sin \phi \\ z = r \cos \theta \end{array} \right\}; J = r^2 \sin \theta$$

In spherical co-ordinates, we have

Thus, $x^2 + y^2 + z^2 = a^2$ becomes $r^2 = a^2$ i.e., $r = a$
 and $x^2 + y^2 = z^2$ becomes $r^2 \sin^2 \theta (\cos^2 \phi + \sin^2 \phi) = r^2 \cos^2 \theta$
 i.e., $\sin^2 \theta = \cos^2 \theta$ i.e. $\theta = \pi/4$.

Clearly, the volume shown in the figure (Fig. 5.73) is one-fourth, i.e. in first quadrant only and, in the common region,

$$\left. \begin{array}{l} r \text{ varies from } 0 \text{ to } a, \\ \theta \text{ varies from } 0 \text{ to } \frac{\pi}{4}, \\ \phi \text{ varies from } 0 \text{ to } \frac{\pi}{2} \end{array} \right\}$$

Hence the required volume,

$$\begin{aligned} V &= 2 \left[4 \int_0^{\pi/2} \int_0^{\pi/4} \int_0^a r^2 \sin \theta dr d\theta d\phi \right] \\ &= 8 \int_0^{\pi/2} \int_0^{\pi/4} \left(\int_0^a r^2 dr \right) \sin \theta d\theta d\phi \\ &= 8 \int_0^{\pi/2} \int_0^{\pi/4} \left(\frac{r^3}{3} \right)_0^a \sin \theta d\theta d\phi \\ &= \frac{8}{3} a^3 \int_0^{\pi/2} [-\cos \theta]_0^{\pi/4} d\phi \\ &= \frac{8}{3} a^3 \left(1 - \frac{1}{\sqrt{2}} \right) \int_0^{\pi/2} d\phi \\ &= \frac{4\pi a^3}{3} \left(1 - \frac{1}{\sqrt{2}} \right) \end{aligned}$$

Alternately: In polar-cylindrical co-ordinates, intersection of the two curves $x^2 + y^2 + z^2 = a^2$ and $x^2 + y^2 = z^2$ results in $z^2 + z^2 = a^2$ or $z^2 = \frac{a^2}{2}$.

Further, $x^2 + y^2 = a^2 - z^2 = a^2 - \frac{a^2}{2} = \frac{a^2}{2} \Rightarrow r = \frac{a}{\sqrt{2}}$, i.e. r varies from 0 to $\frac{a}{\sqrt{2}}$

$$\text{Hence, } V = 2 \int_0^{2\pi} \int_0^{a/\sqrt{2}} (\sqrt{a^2 - r^2} - r) r dr d\theta$$

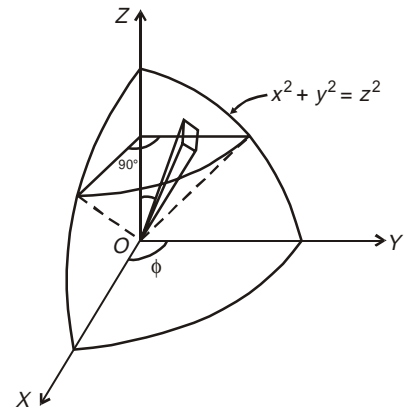

Fig. 5.73

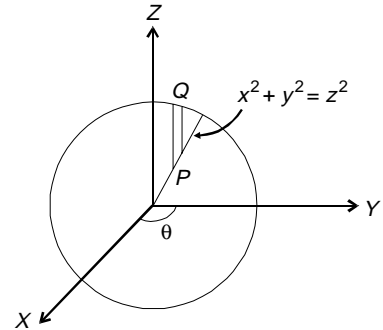

Fig. 5.74

$\therefore P$ lies on the cone whereas Q lies on the sphere as a function of (r, θ)

$$\begin{aligned}
 &= 2 \int_0^{a/\sqrt{2}} (r\sqrt{a^2 - r^2} - r^2) \left(\int_0^{2\pi} d\theta \right) dr \\
 &= 4\pi \left[-\frac{1}{3}(a^2 - r^2)^{3/2} - \frac{r^3}{3} \right]_0^{a/\sqrt{2}} \left[\text{since } r(a^2 - r^2)^{1/2} = \frac{-1}{3} \left(-3r(a^2 - r^2)^{1/2} \right) = \frac{-1}{3} d(a^2 - r^2)^{3/2} \right] \\
 &= 4\pi \left[-\frac{1}{3} \frac{a^3}{2\sqrt{2}} - \frac{1}{3} \frac{a^3}{2\sqrt{2}} + \frac{a^3}{3} \right] \\
 &= \frac{4\pi a^3}{3} \left[1 - \frac{1}{\sqrt{2}} \right]
 \end{aligned}$$

Example 56: By changing to spherical polar co-ordinate system, prove that

$$\iiint_V \sqrt{1 - \frac{x^2}{a^2} - \frac{y^2}{b^2} - \frac{z^2}{c^2}} \, dx \, dy \, dz = \frac{\pi}{4} abc \text{ where } V = \left\{ (x, y, z) : \frac{x^2}{a^2} + \frac{y^2}{b^2} + \frac{z^2}{c^2} \leq 1 \right\}$$

Solution: Taking $\left. \begin{array}{l} \frac{x}{a} = u, \\ \frac{y}{b} = v, \\ \frac{z}{c} = w \end{array} \right\}$, so that $\frac{x^2}{a^2} + \frac{y^2}{b^2} + \frac{z^2}{c^2} \leq 1 \Rightarrow u^2 + v^2 + w^2 \leq 1$

Now transformation co-efficient,

$$|J| = \begin{vmatrix} \frac{\partial x}{\partial u} & \frac{\partial x}{\partial v} & \frac{\partial x}{\partial w} \\ \frac{\partial y}{\partial u} & \frac{\partial y}{\partial v} & \frac{\partial y}{\partial w} \\ \frac{\partial z}{\partial u} & \frac{\partial z}{\partial v} & \frac{\partial z}{\partial w} \end{vmatrix} = \begin{vmatrix} a & 0 & 0 \\ 0 & b & 0 \\ 0 & 0 & c \end{vmatrix} = abc$$

$$\begin{aligned}
 \therefore V &= \iiint_{V(x,y,z)} \sqrt{1 - \frac{x^2}{a^2} - \frac{y^2}{b^2} - \frac{z^2}{c^2}} \, dx \, dy \, dz \\
 &= \iiint_{V(u,v,w)} \sqrt{1 - u^2 - v^2 - w^2} (abc) \, du \, dv \, dw
 \end{aligned}$$

To transform to polar spherical co-rodinate system, let $\left. \begin{array}{l} u = r \sin \theta \cos \phi, \\ v = r \sin \theta \sin \phi, \\ w = r \cos \theta \end{array} \right\}$

Then $V_{(u,v,w)} = \{(u, v, w) : u^2 + v^2 + w^2 \leq 1, u \geq 0, v \geq 0, w \geq 0\}$ reduces to

$$V_{(r,\theta,\phi)} = \{r^2 \leq 1 \text{ i.e., } 0 \leq r \leq 1, 0 \leq \theta \leq \pi, 0 \leq \phi \leq 2\pi\}$$

$$\therefore = \iiint_{V(u,v,w)} \sqrt{1 - u^2 - v^2 - w^2} abc \, du \, dv \, dw$$

$$= \iiint_{V''(r,\theta,\phi)} abc\sqrt{1-r^2} |J| dr d\theta d\phi \quad \text{where } |J| = r^2 \sin \theta$$

$$\Rightarrow V''_{(r,\theta,\phi)} = abc \int_{\phi=0}^{\phi=2\pi} \left(\int_0^{\pi} \left(\int_0^1 \sqrt{1-r^2} r^2 dr \right) \sin \theta d\theta \right) d\phi$$

Now put $r = \sin t$ so that $dr = \cos t dt$ and for $r = 0, t = 0,$
 $r = 1, t = \frac{\pi}{2}$

$$\begin{aligned} \therefore V''_{(r,\theta,\phi)} &= abc \int_0^{2\pi} \left(\int_0^{\pi} \left(\int_0^{\pi/2} \cos t \sin^2 t \cos t dt \right) \sin \theta d\theta \right) d\phi \\ &= abc \int_0^{2\pi} \left(\int_0^{\pi} \left[\frac{(2-1) \cdot (2-1) \pi}{(2+2)(4-2) 2} \right] \sin \theta d\theta \right) d\phi \\ &= abc \int_0^{2\pi} \left(\int_0^{\pi} \left(\frac{1}{4} \frac{1}{2} \frac{\pi}{2} \right) \sin \theta d\theta \right) d\phi \\ &= \frac{\pi abc}{16} \int_0^{2\pi} [-\cos \theta]_0^{\pi} d\phi \\ &= \frac{\pi abc}{16} \int_0^{2\pi} 2 d\phi = \frac{\pi abc}{8} \int_0^{2\pi} d\phi = \frac{\pi^2 abc}{4}. \end{aligned}$$

Example 57: By change of variable in polar co-ordinate, prove that

$$\int_0^1 \int_0^{\sqrt{1-x^2}} \int_0^{\sqrt{1-x^2-y^2}} \frac{dz dy dx}{\sqrt{1-x^2-y^2-z^2}} = \frac{\pi^2}{8}.$$

OR

Evaluate the integral being extended to octant of the sphere $x^2 + y^2 + z^2 = 1$.

OR

Evaluate above integral by changing to polar spherical co-ordinate system.

Solution: Simple Evaluation:

$$I = \int_0^1 dx \int_0^{\sqrt{1-x^2}} dy \int_0^{\sqrt{1-x^2-y^2}} \frac{dz}{\sqrt{1-x^2-y^2-z^2}}$$

Treating $\frac{1}{\sqrt{(1-x^2-y^2)-z^2}}$ as $\frac{1}{\sqrt{a^2-z^2}}$

$$I = \int_0^1 dx \int_0^{\sqrt{1-x^2}} \left(\left| \sin^{-1} \frac{z}{a} \right|_0^{\sqrt{1-x^2-y^2}} \right) dy$$

$$\begin{aligned}
 &= \int_0^1 dx \int_0^{\sqrt{1-x^2}} \left(\sin^{-1} \frac{z}{\sqrt{1-x^2-y^2}} \Big|_0^{\sqrt{1-x^2-y^2}} \right) dy, \text{ as } a = \sqrt{1-x^2-y^2} \\
 &= \int_0^1 dx \int_0^{\sqrt{1-x^2}} \left(\frac{\pi}{2} - 0 \right) dy \\
 &= \frac{\pi}{2} \int_0^1 \left((y)_0^{\sqrt{1-x^2}} \right) dx \\
 &= \frac{\pi}{2} \int_0^1 \sqrt{1-x^2} dx \\
 &= \frac{\pi}{2} \left[\frac{x\sqrt{1-x^2}}{2} + \frac{1}{2} \sin^{-1} x \right]_0^1, \text{ using } \int \sqrt{a^2-x^2} dx = \frac{x\sqrt{a^2-x^2}}{2} + \frac{a^2}{2} \sin^{-1} \frac{x}{a} \\
 &= \frac{\pi}{2} \left[0 + \frac{1}{2} \frac{\pi}{2} \right] = \frac{\pi^2}{8}
 \end{aligned}$$

By change of variable to polar spherical co-ordinates, the region of integration

$$V = \{(x, y, z); x^2 + y^2 + z^2 \leq 1; x \geq 0, z \geq 0, y \geq 0.\}$$

becomes $I = \left\{ (r, \theta, \phi); r^2 \leq 1, \text{ i.e. } 0 \leq r \leq 1, 0 \leq \theta \leq \frac{\pi}{2}, 0 \leq \phi \leq \frac{\pi}{2} \right\}$

where $\left. \begin{aligned} x &= r \sin \theta \cos \phi, \\ y &= r \sin \theta \sin \phi, \\ z &= r \cos \theta \end{aligned} \right\}$

Now $J = \frac{\partial(x, y, z)}{\partial(r, \theta, \phi)} = \text{coefficient of transformation} = r^2 \sin \theta.$

whence $\iiint_V \frac{dx dy dz}{\sqrt{1-x^2-y^2-z^2}} = \int_0^{\pi/2} \int_0^{\pi/2} \int_0^1 \frac{r^2 \sin \theta}{\sqrt{1-r^2}} dr d\theta d\phi$

$$I = \int_0^{\pi/2} d\phi \int_0^{\pi/2} \left(\sin \theta \left(\int_0^1 \frac{r^2}{\sqrt{1-r^2}} dr \right) \right) d\theta$$

Let $r = \sin t$ so that $dr = \cos t dt$. Further, when $r = 0, t = 0,$
 $r = 1, t = \frac{\pi}{2}$

$\therefore I = \int_0^{\pi/2} d\phi \int_0^{\pi/2} \sin \theta d\theta \int_0^{\pi/2} \frac{\sin^2 t}{\cos t} \cdot \cos t dt$
 $= \int_0^{\pi/2} d\phi \int_0^{\pi/2} d\theta \sin \theta \left[\frac{1}{2} \cdot \frac{\pi}{2} \right];$

$$\begin{aligned}
&= \frac{\pi}{4} \int_0^{\pi/2} d\phi \int_0^{\pi/2} \sin \theta d\theta \\
&= \frac{\pi}{4} \int_0^{\pi/2} d\phi (-\cos \theta) \Big|_0^{\pi/2} \\
&= \frac{\pi}{4} \phi \Big|_0^{\pi/2} = \frac{\pi^2}{8}.
\end{aligned}$$

Example 58: Find the volume of the ellipsoid $\frac{x^2}{a^2} + \frac{y^2}{b^2} + \frac{z^2}{c^2} = 1$ by changing to polar co-ordinates. [PTU, 2007]

Solution: We discuss this problem under change of variables.

Take $\frac{x}{a} = X, \frac{y}{b} = Y, \frac{z}{c} = Z$ so that $J = \frac{\partial(x, y, z)}{\partial(X, Y, Z)} = abc$

\therefore The required volume,

$$\begin{aligned}
V &= \iiint dx dy dz = \iiint |J| dX dY dZ \\
&= abc \iiint dX dY dZ, \text{ taken throughout the sphere } X^2 + Y^2 + Z^2 = 1.
\end{aligned}$$

Change this new system (X, Y, Z) to spherical polar co-ordinates (r, θ, ϕ) by taking

$$\left. \begin{aligned} X &= r \sin \theta \cos \phi, \\ Y &= r \sin \theta \sin \phi, \\ Z &= r \cos \theta \end{aligned} \right\} \text{ so that } J = \frac{\partial(X, Y, Z)}{\partial(r, \theta, \phi)} = r^2 \sin \theta,$$

$$V = abc \iiint |J| dr d\theta d\phi = abc \iiint r^2 \sin \theta dr d\theta d\phi$$

taken throughout the sphere $r^2 \leq 1$, i.e. $0 \leq r \leq 1, 0 \leq \theta \leq \pi, 0 \leq \phi \leq 2\pi$

On considering the symmetry,

$$\begin{aligned}
V &= abc \cdot 8 \int_0^{\pi/2} \left(\int_0^{\pi/2} \left(\int_0^1 r^2 dr \right) \sin \theta d\theta \right) d\phi \\
&= 8 abc \int_0^{\pi/2} \left(\int_0^{\pi/2} \frac{r^3}{3} \Big|_0^1 \sin \theta d\theta \right) d\phi \\
&= \frac{8}{3} abc \int_0^{\pi/2} [-\cos \theta]_0^{\pi/2} d\phi \\
&= \frac{8}{3} abc \int_0^{\pi/2} 1 \cdot d\phi \\
&= \frac{8}{3} abc \phi \Big|_0^{\pi/2} = \frac{8}{3} abc \frac{\pi}{2} = \frac{4}{3} \pi abc
\end{aligned}$$

Miscellaneous Problem

Example 59: Evaluate the surface integral $I = \iint_S (x^3 dy dz + x^2 y dz dx + x^2 z dx dy)$.

where S is the surface bounded by $z = 0$, $z = b$, $x^2 + y^2 = a^2$.

OR

By transformation to a triple Integral, evaluate $I = \iiint_S (x^3 dy dz + x^2 y dz dx + x^2 z dx dy)$, where S is the surface bounded by $z = 0$, $z = b$, $x^2 + y^2 = a^2$.

Solution: On making use of Green's Theorem,

$$\begin{aligned} I &= \int_{-a}^a \int_0^b (\sqrt{a^2 - y^2})^3 dz dy - \int_{-a}^a \int_0^b (-\sqrt{a^2 - y^2})^3 dz dy \\ &\quad + \int_{-a}^a \int_0^b x^2 \sqrt{a^2 - x^2} dz dx - \int_{-a}^a \int_{-a}^a x^2 (-\sqrt{a^2 - x^2}) dz dx \\ &\quad + \int_{-a}^a \int_{-\sqrt{a^2 - y^2}}^{\sqrt{a^2 - y^2}} (a^2 - y^2) b dx dy - \int_{-a}^a \int_{-\sqrt{a^2 - y^2}}^{\sqrt{a^2 - y^2}} 0 dx dy \end{aligned}$$

Using Divergence Theorem,

$$\begin{aligned} I &= \iiint_V (3x^2 + x^2 + x^2) dx dy dz \\ &= 4 \int_0^a \left[\int_0^{\sqrt{a^2 - x^2}} \left(\int_0^b dz \right) dy \right] 5x^2 dx \\ &= 4 \int_0^a \left[\int_0^{\sqrt{a^2 - x^2}} b dy \right] 5x^2 dx \\ &= 20b \int_0^a x^2 \sqrt{a^2 - x^2} dx \\ &= \frac{5}{4} \pi a^4 b. \end{aligned}$$

Note: As direct calculation of the integral may prove to be instructive. The evaluation of the integral can be carried out by calculating the sum of the integrals evaluated over the projections of the surface S on the co-ordinate planes. Thus, which upon evaluation is seen to check with the result already obtained. It should be noted that the angles α, β, γ are made by the exterior normals in the +ve direction of the co-ordinate axes.

ANSWERS

Assignment 1

- | | |
|-----------------------------------|--------------------|
| 1. $\left(\frac{\pi^2}{4}\right)$ | 2. $\frac{a^4}{3}$ |
| 3. $\frac{1}{ab}$ | 6. $\frac{\pi}{4}$ |

Assignment 2

- | | |
|---|---|
| 1. $\int_0^a \left(\int_0^x \frac{x}{x^2 + y^2} dy \right) dx$ | 3. $\int_a^{\text{asin } \alpha} \int_0^{y \cos \alpha} f(x, y) dx dy + \int_a^a \int_0^{\sqrt{a^2 - y^2}} f(x, y) dx dy$ |
| 2. $\int_0^a \int_{-\sqrt{a^2 - x^2}}^{\sqrt{a^2 - x^2}} f(x, y) dy dx$ | 4. $\int_0^{ma} \int_{\frac{y}{l}}^{\frac{y}{l}} f(x, y) dx dy + \int_{ma}^{la} f(x, y) dx dy$ |

Assignment 3

- | | | |
|---------------------|----------------------------------|---|
| 1. $\frac{4a^2}{3}$ | 2. $\frac{3}{2} \pi (b^4 - a^4)$ | 3. $a^2 \left(\frac{3}{4} \pi + \frac{4}{3} \right)$ |
|---------------------|----------------------------------|---|

Assignment 4

2. $\frac{1}{10}$ sq. units

Assignment 5

- | | |
|------------------------------|-------------------------------------|
| 1. $\frac{\pi a^4}{8}$ units | 2. $\frac{a^3}{12} (\pi + 2)$ units |
| 3. $\frac{2\pi}{9}$ units | 4. $\frac{\pi}{4}$ units |

Assignment 6

- | | |
|-----------|---|
| 1. 1 | 2. $\frac{8}{9} a^3 bc (3 + 2ab^2 + 2ac^2)$ |
| 3. 8π | 4. $\frac{8}{9} \log 2 - \frac{19}{9}$ |

Assignment 7

- | | |
|---------------------|---|
| 1. $\frac{1}{6lmn}$ | 2. $abc \left(\frac{\pi}{4} - \frac{13}{24} \right)$ |
|---------------------|---|

Assignment 8

1. $abc/6$

2. $\frac{3\pi a^3}{2}$

Assignment 9

1. $\frac{4\pi ab^2}{3}$

2. $\frac{2}{3}\pi a^2$

3. $2\pi^2 a^3$

4. $\frac{\pi a^3}{4} \left\{ \frac{1}{\sqrt{2}} \log(\sqrt{2} + 1) - \frac{1}{3} \right\}$